

# ECON<sup>®</sup> Series 3300 NCS Smart Valve Positioner with non contact sensor



Scan for manual



# Contents

<b>ATTENTION</b> .....	<b>4</b>
<b>1 INTRODUCTION</b> .....	<b>5</b>
1.1 GENERAL INFORMATION FOR THE USERS .....	5
1.2 MANUFACTURER WARRANTY .....	5
1.3 EXPLOSION PROOF WARNING (ONLY FOR INTRINSIC SAFETY TYPE POSITIONERS) .....	5
<b>2 PRODUCT DESCRIPTION</b> .....	<b>6</b>
2.1 GENERAL .....	6
2.2 MAIN FEATURES AND FUNCTIONS .....	6
2.3 TYPE PLATE DESCRIPTION.....	8
2.4 PRODUCT SPECIFICATION .....	9
2.5 CERTIFICATIONS.....	10
2.6 PARTS AND ASSEMBLY .....	11
2.7 PRODUCT DIMENSIONS .....	12
<b>3 INSTALLATION</b> .....	<b>13</b>
3.1 SAFETY.....	13
3.2 FIGURE 3301 AND 3302 INSTALLATION .....	13
3.2.1 Installation Steps .....	14
3.3 FIGURE 3301 DIRECT-MOUNTING INSTALLATION.....	16
3.3.1 Installation Steps .....	16
3.4 FIGURE 3303 AND 3304 INSTALLATION .....	17
3.4.1 Bracket information.....	17
<b>4 CONNECTIONS</b> .....	<b>18</b>
4.1 SAFETY.....	18
4.2 SUPPLY PRESSURE CONDITION.....	19
4.3 PIPING CONDITION.....	19
4.4 CONNECTION – ACTUATOR.....	19
4.4.1 Single acting actuator – Figure 3301 & 3303.....	19
4.4.2 Double acting actuator – Figure 3302 & 3304.....	19
4.5 CONNECTION – POWER .....	20
4.5.1 Safety.....	20
4.5.2 Terminal Overview.....	20
4.5.3 Ground.....	21
<b>5 ADJUSTMENTS</b> .....	<b>21</b>
5.1 AUTO/MANUAL SWITCH (A/M SWITCH).....	21
5.2 VARIABLE ORIFICE ADJUSTMENT .....	22
5.3 OPTION PCB ADJUSTMENT .....	22
<b>6 AUTO CALIBRATION AND PCB OPERATION</b> .....	<b>24</b>
6.1.1 WARNING.....	24
6.1.2 LCD DISPLAY AND BUTTONS.....	24
6.1.3 MENU LEVELS.....	25
6.1.4 Run Mode (RUN).....	26
6.1.5 Configuration and Operation.....	27
6.1.6 Calibration (CALib).....	32
6.1.6.1 Acting Type (SINGLE / DOUBLE).....	33

6.1.6.2 Auto Calibration 1 (AUTO 1).....	33
6.1.6.3 Auto Calibration 2 (AUTO 2).....	34
<b>6.2 MANUAL OPERATION (MAN OPER).....</b>	<b>35</b>
6.2.1 Manual Operation by Set position (MAN SP).....	35
6.2.2 Manual Operation by Manipulator Value (MAN MV).....	35
6.3 Control Parameters (CTL PARM) .....	36
6.3.1 Dead Band (dEAdbANd).....	36
6.3.2 Forward P parameter (KP UP) and reverse P parameter (KP dN).....	37
6.3.3 Forward Integral time parameter (TI UP) and reverse Integral time parameter (TI dN).....	37
6.3.4 Forward D parameter (Kd UP) and reverse D parameter (Kd dN).....	38
6.3.5 GAP Parameter (GAP).....	38
6.3.6 GAP P parameter (GP).....	39
6.3.7 GAP I parameter (GI).....	39
6.3.8 GAP D parameter (Gd).....	40
6.3.9 Auto Dead band Mode (AUTO db).....	40
6.3.10 Performance Mode (PER).....	40
6.4 Input Configuration.....	41
6.4.1 Signal Direction (SIG NORM / REVS).....	41
6.4.2 Split Range Mode (SPLIT).....	42
6.4.3 Custom Split Range Zero (CST ZERO).....	42
6.4.4 Custom Split Range End (CST END).....	43
6.4.5 Valve Flow Characterization Curves (CHAR).....	43
6.4.6 User Set Characterization 5 points (U5).....	44
6.4.7 User Set Characterization 21 Points (U21).....	45
6.4.8 Tight Shut Open (TSHUT OP).....	46
6.4.9 Tight Shut Close (TSHUT CL).....	48
6.4.10 Target Position Ramp Up Rate (RAMP UP) and Target Position Ramp Down Rate (RAMP dN).....	49
6.5 Output Configuration (OUT CFG).....	50
6.5.1 Position Transmitter direction (PTM NORM / REVS).....	50
6.5.2 Position Transmitter Zero / End (PTM ZERO / ENd).....	51
6.5.3 HART Feedback Direction (HT NORM / REVS).....	52
6.5.4 Back Calculation (bACKCAL off / on).....	52
6.6 Device Configuration (dEV CFG).....	53
6.6.1.1 Acting Setting (ACT REVS / dIR).....	53
6.6.1.2 Linear Lever Type (LEVT Std / AdT).....	54
6.6.1.3 Linear Interpolatiojn (ITP off/ on).....	54
6.6.1.4 Lock of Parameters (Write Protect, W UNLOCK / LOCK).....	55
6.6.1.5 Actual Position View Mode (View Mode, VI NORM / REVS).....	55
6.6.1.6 Polling address setting (POL Addr).....	56
6.6.1.7 Factory Reset (dEFAULT off / on).....	56
6.6.1.8 Postioner Self-Test (SELFTEST).....	57
6.6.2 Diagnose Mode (dIAGNd).....	57
6.6.2.1 Default Alarm Settings.....	58
6.6.2.2 Process Status (PS).....	59
6.6.2.3 Device Status (dS).....	60
6.6.2.4 View Monitoring Counts (VI CNTS).....	61
6.6.2.5 Diagnostic Limit Configuration (LIMT CFG).....	62
6.6.2.6 Reset Alarm Status (RST ALRM off / on).....	62

6.6.2.7 View Event Log (EVT LOG).....63  
 6.6.2.8 Partial Stroke Test Record (View PST Result Record, PST RSLT).....64  
 6.6.2.9 PST Configuration (PST CFG).....65  
 6.6.2.10 Run PST (PST NOW).....67  
 6.6.2.11 Periodic PST Test (PST Schedule, PST SCHd oFF).....67  
 6.6.3 Position information (INFO).....68  
 6.6.4 Error codes during automatic calibration.....69  
 6.6.5. Staus and Alarm code.....69  
**7 Main Software Map**.....72  
**8 Manufacturer contact details**.....73

**ATTENTION:**

In 2022 a new version of ECON Smart positioner Fig. 3300 is introduced; ECON Smart positioner Fig. 3300 NCS.

This is the manual for the new version, if you have the old version please scan below CR code for the manual for the old version.



Scan for manual

OLD  
 Potentiometer as feedback sensor

NEW  
 Non Contact Sensor (NCS) as feedback sensor  
 New Software with more options  
 New PCB with new terminal connector  
 New Option module for 4-20 mA feed back transmitter  
 New Option module for 4-20 mA feed back transmitter with HART

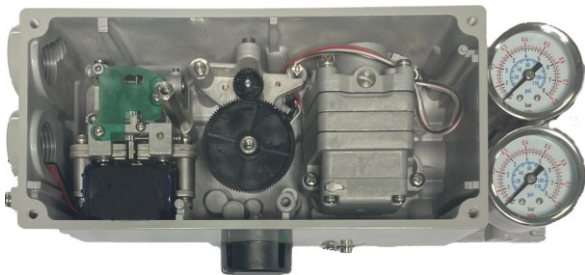

## 1 Introduction

### 1.1 General Information for the users

Thank you for purchasing the ECON® series 3300 Smart Valve Positioner. Each product has been fully inspected after its production to offer you the highest quality and reliable performance. Please read the product manual carefully prior to installing and commission the product.

- For safety, it is important to follow the instructions in the manual. ERIKS will not be held responsible for any damages caused by user's negligence.
- The manual should be provided to the end-user.
- Any modifications or repairs to the product may only be performed if expressed in this manual.
- The manual can be altered or revised without any prior notice. Any changes in product's specification, design, and/or any components may not be printed immediately but until the following revision of the manual.
- The manual should not be duplicated or reproduced for any purpose without prior approval.

### 1.2 Manufacturer Warranty

- For the safety, it is important to follow the instructions in the manual. Manufacturer will not be responsible for any damages caused by user's negligence.
- Manufacturer will not be responsible for any damages or accidents as a result of any alteration or modification of the product and its parts. If any alteration or modifications are necessary, please contact ERIKS directly.
- Manufacturer warrants the product from the date of original purchase of the product for one (1) year, except as otherwise stated.
- Manufacturer warranty will not cover products that have been subjected to abuse, accidents, alterations, modifications, tampering, negligence, misuse, faulty installation, lack of reasonable care, repair or service in any way that is not contemplated in the documentation for the product, or if the model or serial number has been altered, tampered with, defaced or removed; damages that occurs in shipment, due to weather conditions, failure due to power surge, or cosmetic damage. Improper or incorrectly performed maintenance will void this limited warranty.

### 1.3 Explosion Proof Warning (Only for Intrinsic safety type positioners)

Please ensure the unit is being used and installed in conformity with local, regional, and national explosion proof legislation, within the proper safety barrier environment.

- Refer to paragraph 2.6 "Certifications".
- Explosion proof type of cables and gaskets should be used, when inflammable gases are present at the installation site.
- Positioner has 2 ports for power connection. Explosion proof type wires and packing should be used. Blind plug is required when any port is not being used.
- Ring terminal with surface area of more than 1.25mm<sup>2</sup> with M4 spring washer should be used to



connect the power.

- For external ground terminal, ring terminal with surface area of more than 5.5mm<sup>2</sup> should be used.
- Wiring in these applications must meet the requirements.
- Substitution of components may impair intrinsic safety.
- WARNING - EXPLOSION HAZARD – Substitution of components may impair suitability for Class I, Division 2.
- “AVERTISSEMENT – RISQUE D’EXPLOSION – Remplacement des composants peut nuire à la conformité de Class I, Division 2.
- EXPLOSION HAZARD. Do not connect or disconnect wiring unless all sources of power have been removed or the area is known to be non-hazardous.  
(French) RISQUE D’EXPLOSION. Ne pas raccorder ou débrancher le câblage à moins Toutes les sources d’énergie ont été enlevées ou la zone est connue pour être non dangereux.
- The enclosure of ECON<sup>®</sup> series 3300 contains aluminum, which is considered to constitute a potential risk of ignition when subjected to impact or friction.
- Care must be used during installation in locating this equipment to prevent impact or friction
- Some of the enclosure parts are made of non-metallic materials, to prevent the risk of electrostatic sparking. Clean the enclosure only with a damp cloth.
- The product must be installed in such a manner as to minimize the risk of impact or friction with other metal surfaces.
- For Intrinsically Safe installations, the product must be connected to suitably rated intrinsically safe equipment, and must be installed in accordance with applicable intrinsically safe installation standards.
- Special conditions for safe use:  
The ambient temperature range deviates from the standard temperature range and amounts to:  
Equipment must be protected from risk of mechanical impact hazard.  
Temperature class T5 / T100°C: -40°C to +60°C  
Temperature class T6 / T85°C: -40°C to +40°C

## 2 Product Description

### 2.1 General

ECON<sup>®</sup> series 3300 Smart Valve Positioner accurately controls valve stroke in response to an input signal of 4-20mA from a process controller. A built-in micro-processor optimizes the positioner’s performance and provides unique functions such as **Auto-Calibration, PID Controlled and HART<sup>®</sup> Protocol Communications.**

### 2.2 Main Features and Functions

- LCD display enables users to monitor the positioner status.
- Easy operation method of using 4 buttons



- When unexpected situation like momentary blackout happens, our positioner boot-time only take 0.5 second and this can minimize the travel of valve which consequentially increase the safety of system.
- Positioner operates normally during sudden changes in supply pressure.
- Low air consumption level and low voltage use (8.5 V) yield to lower plant operating costs. The series 3300 is compatible with most of controllers.
- Variable orifices can be used to minimize the hunting occurrence and optimize operating conditions.
- Valve system becomes more stable by outputting analog feedback signal. Feedback is greatly improved by the accuracy and fast response of the series 3300.
- Different valve characteristics can be adjusted – Linear, Quick Open, Equal Percentage, and Custom which user can make 5 or 18 points characterizations.
- Tight Shut – Close and Shut - Open can be set.
- PID parameters can be adjusted in the field without any additional communicator.
- A/M switch can be used to direct supply air to the actuator or to manually operate the positioner or valve.
- Split range 4-12mA or 12-20mA can be set.
- Operating temperature is -30 ~ 85°C.
- Manual Operation allows the user to operate the valve manually.
- It has IP66 ingress protection grade.
- Epoxy polyester powder coating resists the corrosion process.
- Maintenance of the positioner is easy because of modularized inner structure.
- SIL2 certified.

2.3 Type Plate Description

Standard – Non-explosion proof types

<p><b>econ® Smart Positioner</b> www.eriks.com</p> <p><b>Linear single acting Fig.3301</b></p> <p>ERIKS art. no: 14463578 Explosion proof: Non-Explosion Input signal: 4~20mA DC Operating Temperature: -30°C ~ 85°C (-22°F ~ 185°F) Supply Pressure: 0,14 ~ 0,7MPa (20 ~ 101 psi) Serial number:</p> <p>CE</p>	<p><b>econ® Smart Positioner</b> www.eriks.com</p> <p><b>Quarter turn single acting Fig.3303</b></p> <p>ERIKS art. no: 14463577 Explosion proof: Non-Explosion Input signal: 4~20mA DC Operating Temperature: -30°C ~ 85°C (-22°F ~ 185°F) Supply Pressure: 0,14 ~ 0,7MPa (20 ~ 101 psi) Serial number:</p> <p>CE</p>
<p><b>econ® Smart Positioner</b> www.eriks.com</p> <p><b>Linear double acting Fig.3302</b></p> <p>ERIKS art. no: 14463579 Explosion proof: Non-Explosion Input signal: 4~20mA DC Operating Temperature: -30°C ~ 85°C (-22°F ~ 185°F) Supply Pressure: 0,14 ~ 0,7MPa (20 ~ 101 psi) Serial number:</p> <p>CE</p>	<p><b>econ® Smart Positioner</b> www.eriks.com</p> <p><b>Quarter turn double acting Fig.3304</b></p> <p>ERIKS art. no: 14463580 Explosion proof: Non-Explosion Input signal: 4~20mA DC Operating Temperature: -30°C ~ 85°C (-22°F ~ 185°F) Supply Pressure: 0,14 ~ 0,7MPa (20 ~ 101 psi) Serial number:</p> <p>CE</p>

INTRINSIC SAFE TYPES

<p><b>econ®</b> www.eriks.com</p> <p><b>Smart Positioner</b> ECON Fig. 3301 LINEAR SINGLE ACTING</p> <p>ERIKS Flow Control Categorieën 63 2908.T Copieë aan den IJssel The Netherlands</p>	<p>CE 2004 Ex II 2 GD</p> <p>EPS 19 ATEX 1 086 X IECEX EPS 19.0046X</p> <p>MODEL : Fig. 3301 INTRINSIC SAFETY/ NONINCENDIVE : Ex ia IIC T5/T6 Gb Ex ia IIIC T100°C/185°C Db IP 6X INGRESS PROTECTION : IP66 INPUT SIGNAL : 4~20mA DC AMBIENT TEMP. :</p> <p>SUPPLY PRESSURE : 0,14 ~ 0,7 MPa (1,4 ~ 7 bar) UI, II, PI, CI, LI : See certificate or product manual SERIAL NUMBER :</p> <p>⚠ TO PREVENT IGNITION OF FLAMMABLE OR COMBUSTIBLE ATMOSPHERES, DISCONNECT POWER BEFORE SERVICING. WARNING</p>
<p><b>econ®</b> www.eriks.com</p> <p><b>Smart Positioner</b> ECON Fig. 3302 LINEAR DOUBLE ACTING</p> <p>ERIKS Flow Control Categorieën 63 2908.T Copieë aan den IJssel The Netherlands</p>	<p>CE 2004 Ex II 2 GD</p> <p>EPS 19 ATEX 1 086 X IECEX EPS 19.0046X</p> <p>MODEL : Fig. 3302 INTRINSIC SAFETY/ NONINCENDIVE : Ex ia IIC T5/T6 Gb Ex ia IIIC T100°C/185°C Db IP 6X INGRESS PROTECTION : IP66 INPUT SIGNAL : 4~20mA DC AMBIENT TEMP. :</p> <p>SUPPLY PRESSURE : 0,14 ~ 0,7 MPa (1,4 ~ 7 bar) UI, II, PI, CI, LI : See certificate or product manual SERIAL NUMBER :</p> <p>⚠ TO PREVENT IGNITION OF FLAMMABLE OR COMBUSTIBLE ATMOSPHERES, DISCONNECT POWER BEFORE SERVICING. WARNING</p>
<p><b>econ®</b> www.eriks.com</p> <p><b>Smart Positioner</b> ECON Fig. 3303 ROTARY SINGLE ACTING</p> <p>ERIKS Flow Control Categorieën 63 2908.T Copieë aan den IJssel The Netherlands</p>	<p>CE 2004 Ex II 2 GD</p> <p>EPS 19 ATEX 1 086 X IECEX EPS 19.0046X</p> <p>MODEL : Fig. 3303 INTRINSIC SAFETY/ NONINCENDIVE : Ex ia IIC T5/T6 Gb Ex ia IIIC T100°C/185°C Db IP 6X INGRESS PROTECTION : IP66 INPUT SIGNAL : 4~20mA DC AMBIENT TEMP. :</p> <p>SUPPLY PRESSURE : 0,14 ~ 0,7 MPa (1,4 ~ 7 bar) UI, II, PI, CI, LI : See certificate or product manual SERIAL NUMBER :</p> <p>⚠ TO PREVENT IGNITION OF FLAMMABLE OR COMBUSTIBLE ATMOSPHERES, DISCONNECT POWER BEFORE SERVICING. WARNING</p>
<p><b>econ®</b> www.eriks.com</p> <p><b>Smart Positioner</b> ECON Fig. 3304 ROTARY DOUBLE ACTING</p> <p>ERIKS Flow Control Categorieën 63 2908.T Copieë aan den IJssel The Netherlands</p>	<p>CE 2004 Ex II 2 GD</p> <p>EPS 19 ATEX 1 086 X IECEX EPS 19.0046X</p> <p>MODEL : Fig. 3304 INTRINSIC SAFETY/ NONINCENDIVE : Ex ia IIC T5/T6 Gb Ex ia IIIC T100°C/185°C Db IP 6X INGRESS PROTECTION : IP66 INPUT SIGNAL : 4~20mA DC AMBIENT TEMP. :</p> <p>SUPPLY PRESSURE : 0,14 ~ 0,7 MPa (1,4 ~ 7 bar) UI, II, PI, CI, LI : See certificate or product manual SERIAL NUMBER :</p> <p>⚠ TO PREVENT IGNITION OF FLAMMABLE OR COMBUSTIBLE ATMOSPHERES, DISCONNECT POWER BEFORE SERVICING. WARNING</p>



**Precautions**

Be careful not to apply volatile solvent (hardener of instant adhesive, acetone, WD-40, etc.) to the sticker nameplate. Printed contents may be erased.



## 2.4 Product Specification

Figure		3301	3302	3303	3304
Housing Material		Aluminum Die-casting			
Motion type		Linear		Rotary	
Acting Type		Single	Double	Single	Double
Input Signal		4~20mA DC			
Min. Current Signal		Standard : 3.6 mA (NCS type) PTM Internal : 3.7 mA (NCS type) HART or HART+PTM internal : 3.8mA			
Supply Pressure		0.14~0.7 MPa (1.4~7 bar)			
Stroke		10~150 mm		55~110°	
Impedance		Max.500Ω @ 20mA DC			
Air Connection		Rc 1/4 or 1/4 NPT or G 1/4			
Gauge Connection		Rc 1/8" or 1/8" NPT			
Conduit Entry		G 1/2 or 1/2 NPT or M20x1.5P			
Ingress Protection		IP66			
Explosion Proof		ATEX, Ex ia IIC T5/T6 Gb, Ex iaD IIIC T100°C/T85°C Db, IP66			
Operating Temperature		Operating Temp. :-30~85°C			
Ambient Temperature	T5	-40 ~ 60 °C (-40 ~ 140 °F) EAC : -55 ~ 60 °C (-67 ~ 140 °F)			
	T6	-40 ~ 40 °C (-40 ~ 104 °F) EAC : -55 ~ 40 °C (-67 ~ 104 °F)			
Linearity		±0.5% F.S.			
Hysteresis		0.5% F.S.			
Sensitivity		±0.2% F.S.			
Repeatability		±0.3% F.S.			
Flow Capacity		70 LPM (Sup.=0.14 MPa)			
Air Consumption		Below 2 LPM (sup = 0.14 MPa), Below 3 LPM (sup = 0.7MPa)			
Output Characteristic		Linear, Quick Open, EQ%, User Set			
Vibration		No Resonance up to 100Hz @ 6G			
Humidity		5-95% RH @ 40°C			
Communication (Option)		HART® Communication (HART 7)			
Feedback Signal (Option)		4~20mA (DC 9~28V)			
Weight		2 kg (4.4 lb)			

<b>Painting</b>	Epoxy Powder Coating
-----------------	----------------------



Tested under ambient temperature of 20°C, absolute pressure of 760mmHg, and humidity of 65%.

## 2.5 Certifications

### **ATEX**

Type : Intrinsic safety

Rating : II 2G Ex ia IIC T5/T6 Gb, II 2D Ex iaD IIIC T100°C/T85°C Db, IP6X

Certification No. : EPS 12 ATEX 1 456 X

Ambient temperature : -40 ~ +60°C (T5), -40 ~ +40°C (T6)

### **IECEX**

Type : Intrinsic safety

Rating : Ex II 2G Ex ia IIC T5/T6 Gb, Ex II 2D Ex ia IIIC T100°C/T85°C Db, IP6X

Certification No. : IECEX EPS 12.0017X

Ambient temperature : -40 ~ +60°C (T5/T100°C), -40 ~ +40°C (T6/T85°C)

### **Electromagnetic Compatibility (EMC)**

- EMC directive 2014/30/EC from April 2016

- EC Directive for CE conformity marking

### **SIL2 (in a redundant structure up to SIL 3)**

Intended application : Safety function is defined as to move into fail-safe-position, when signal to positioner is interrupted.

**2.6 Parts and Assembly**

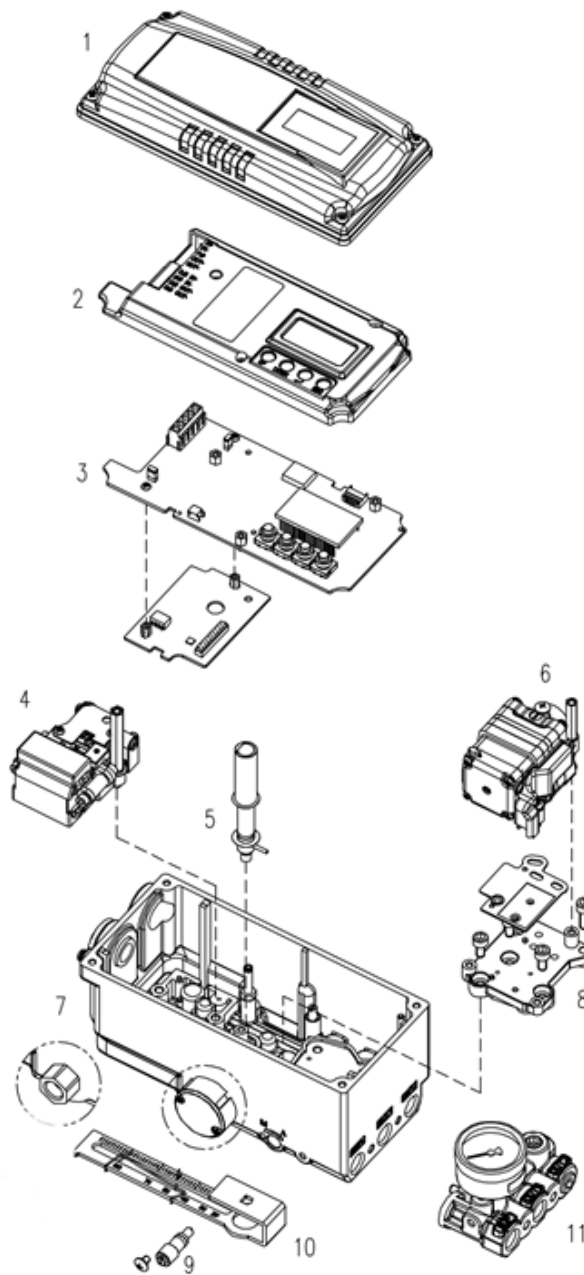

**Figure 3301/3302/3303/3304 exploded view**

1. Base Cover	7. Base body
2. PCB Cover	8. Pilot Block
3. Main PCB	9. Auto Manual Switch
4. Torque Motor	10. Feedback Lever
5. Main Shaft (NCS)	11. Gauge Block
6. Pilot	

**2.7 Product Dimensions**

Figure 3301 and 3302

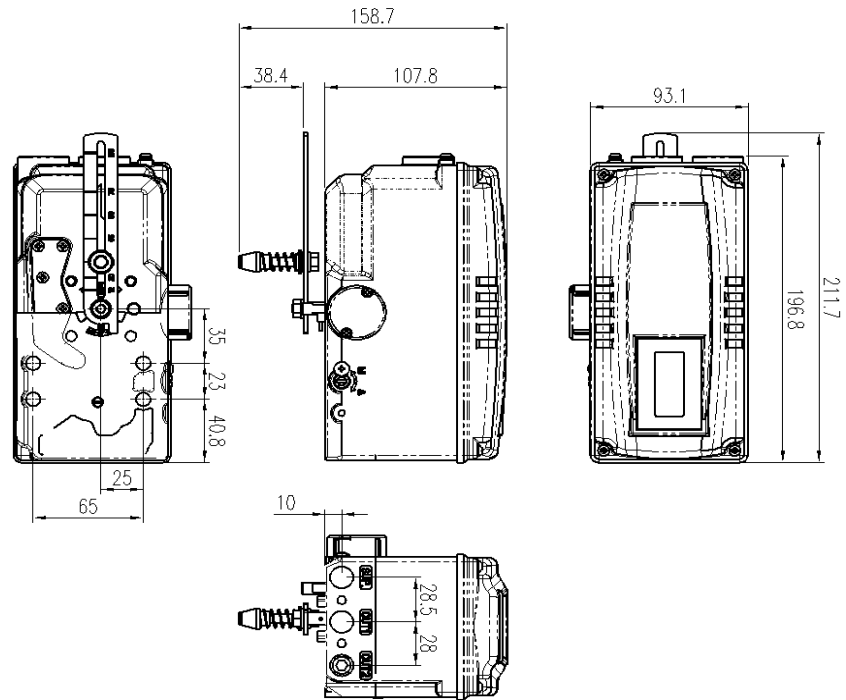
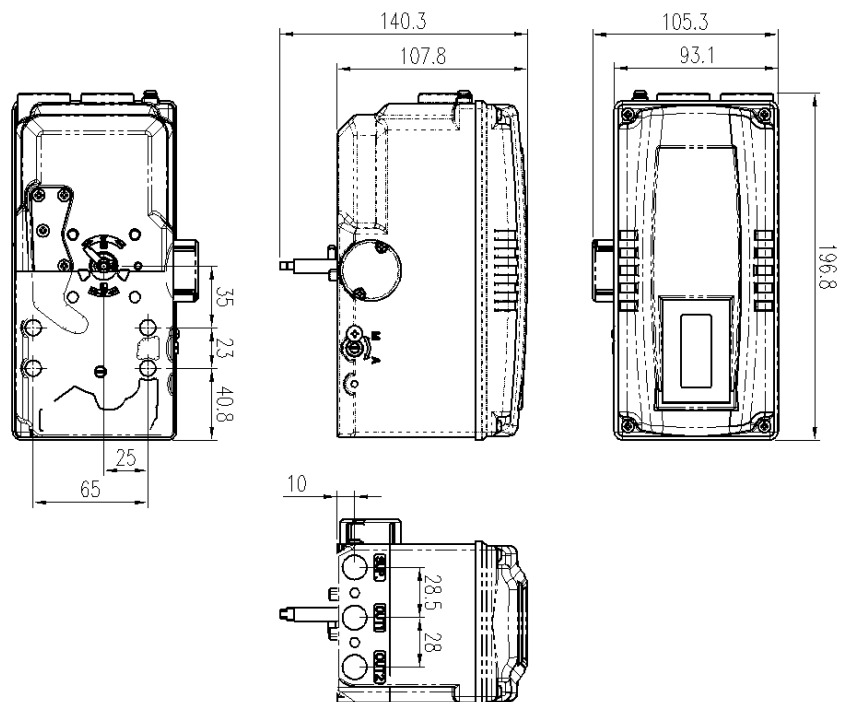

Figure 3303 and 3304



### 3 Installation

#### 3.1 Safety

When installing a positioner, please ensure to read and follow safety instructions.



- Any input or supply pressure to valve, actuator, and / or to other related devices must be turned off.
- Use bypass valve or other supportive equipment to avoid entire system “shut down”.
- Ensure there is no remaining pressure in the actuator.
- The positioner has a vent cover to exhaust internal air and drain internal condensation water. When installing the positioner, make sure the vent cover must be facing downward. Otherwise, the condensation water could cause damage-to PCB

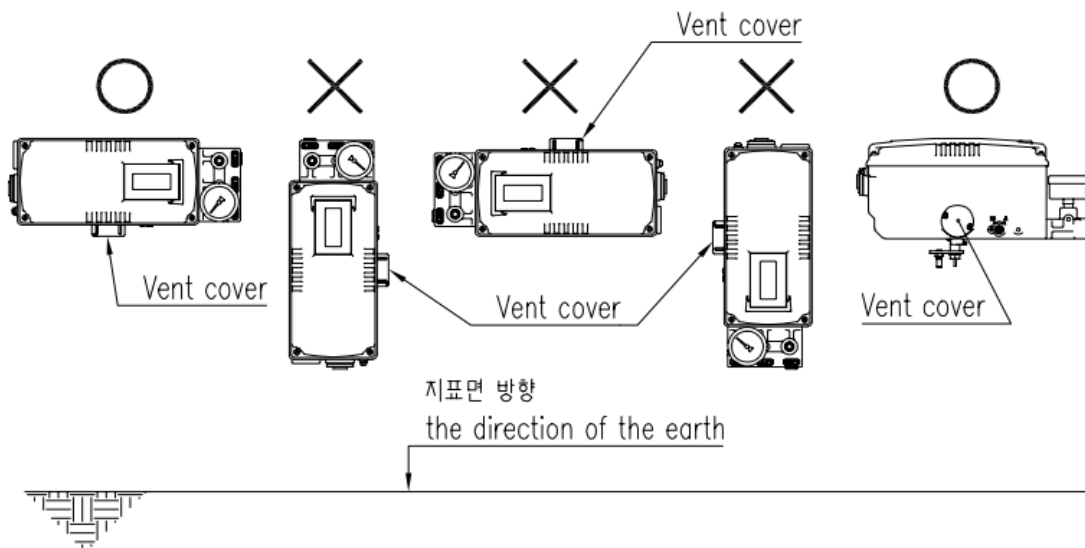

#### 3.2 Figure 3301 and 3302 Installation

Figure 3301 and 3302 should be installed on linear motion valves such as globe or gate type which uses spring return type diaphragm or piston actuators. The following components are supplied in the linear positioner kit:

- Positioner unit
  - Feedback lever and lever spring
  - Bar slide assembly
  - Standard linear bracket
  - 2 pcs x U-bolt M8
  - 2 pcs x M8 hexagonal headed bolts
  - 4 pcs x M8 spring washer
  - 6 pcs x M8 plate washer
  - 4 pcs x M8 nuts
  - ½” NPT gland for 6-8 mm cable diameter
- (air connections and air hose to be supplied by customer)

**3.2.1 Installation Steps**



1. A correct bracket must be used in order to mount the positioner on the actuator yoke. Please consider following important points when a custom bracket is being designed.
  - Positioner's feedback lever must be parallel to the ground at 50% of the valve stroke.

2. Feedback lever connection with the coupling of the actuator should be installed in such a way that the valve stroke length coincides with the corresponding Figure in "mm" marked on the feedback lever. Improper setting may cause poor linearity and may create unnecessary hunting during operation.

Assemble the positioner with the bracket supplied by fastening the bolts. Please refer to the back of the positioner for size of the bolts. The standard bolt size is M8.

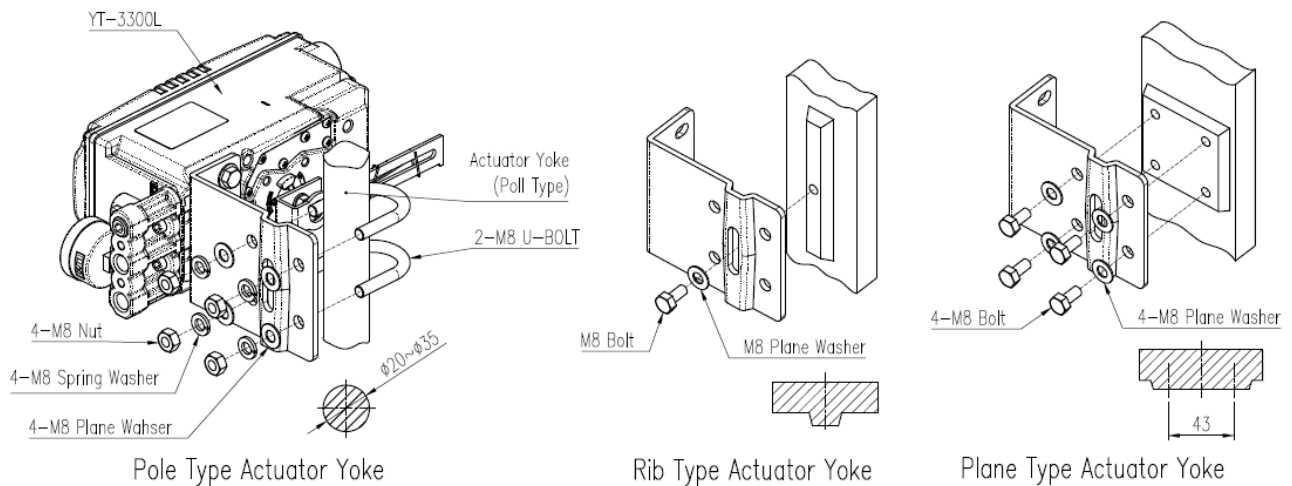
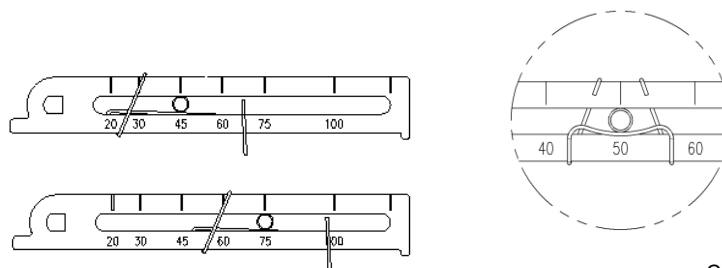

Figure 3301/3302

3. Check the valve stroke. The stroke marks are indicated on the feedback lever of the positioner. Position the connection pin at the number on the feedback lever which corresponds to the desired valve stroke. To adjust, move the bracket, the connection pin or both.



Correct way of Pin Insertion

4. Attach the bar side assembly with the supplied mounting bolts onto the actuator coupling.
5. Mount the positioner with the bracket and the U-bolts onto the actuator yoke – **DO NOT TIGHTEN POSITIONER COMPLETELY.**



6. Connect supply pressure through an air-filter regulator to the actuator temporarily. Supply enough supply pressure to the actuator in order to position the actuator clamp at 50% of the total valve stroke.
7. Insert the connection pin of the feedback lever in to the bar slide assembly. The pin should be inserted when the actuator clamp is at 50% of the total valve stroke.

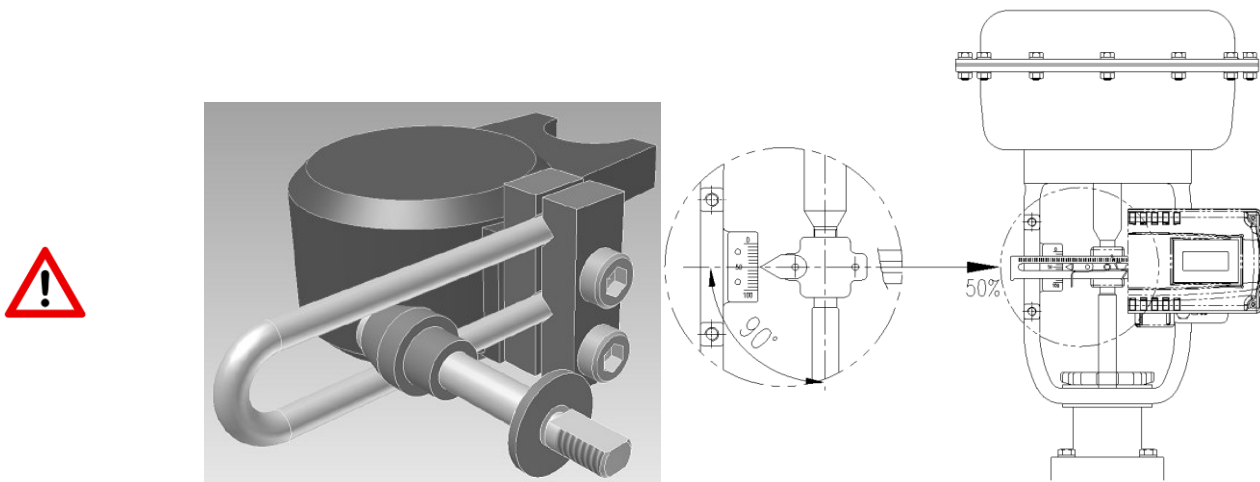

**Correct way to connect feedback lever, connection pin, and lever spring**

8. Check if feedback lever is parallel to the ground at 50% of the valve stroke. If it is not parallel, adjust the bracket or feedback link bar to make parallel. Improper installation may cause poor linearity and may create unnecessary hunting during the operation.
9. After installing the positioner, operate the valve from 0% to 100% stroke by using direct air to the actuator (manual position). On both 0% and 100%, the feedback lever should not touch the lever stopper, which is located on the back of the positioner. If the feedback lever touches the stopper, the positioner should be installed further away from the yoke.

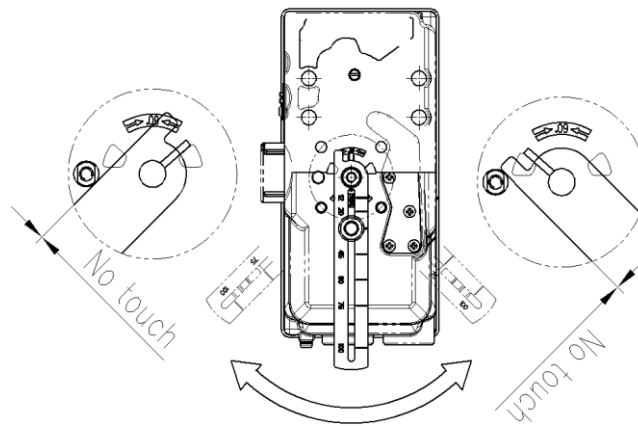

Feedback lever should not touch lever stopper 0% ~ 100% valve stroke.

10. After the installation, tighten all of the bolts on the bracket, the feedback lever, and the connection pin.

### 3.3 Figure 3301 Direct-Mounting Installation

Figure 3301 can be installed on direct-mounting / tube-less type actuators.

#### 3.3.1 Installation Steps

1. Please remove the plug which blocks OUT port on the back of the Figure 3301 unit. OUT ports on the side of the positioner should be blocked by plugs.

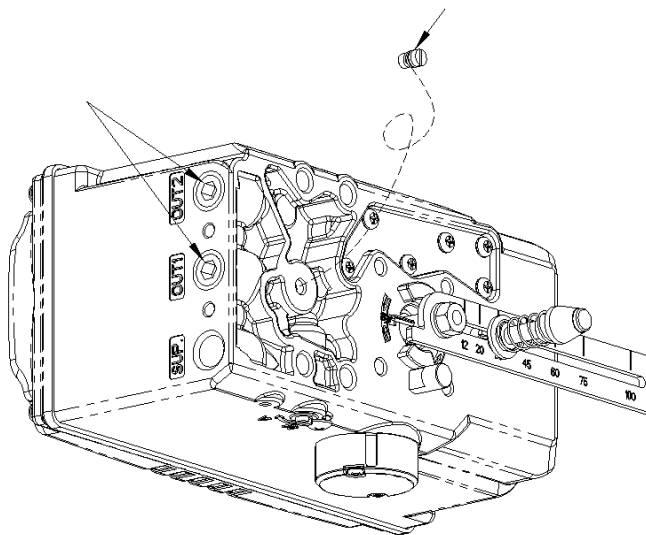

2. Mount Figure 3301 onto actuator's yoke by using 2 bolts. As you mount the positioner, please be careful not to lose O-rings from the air channel. Please ensure that the lever adapter connection has been properly installed onto actuator's stem before tightly fastened.

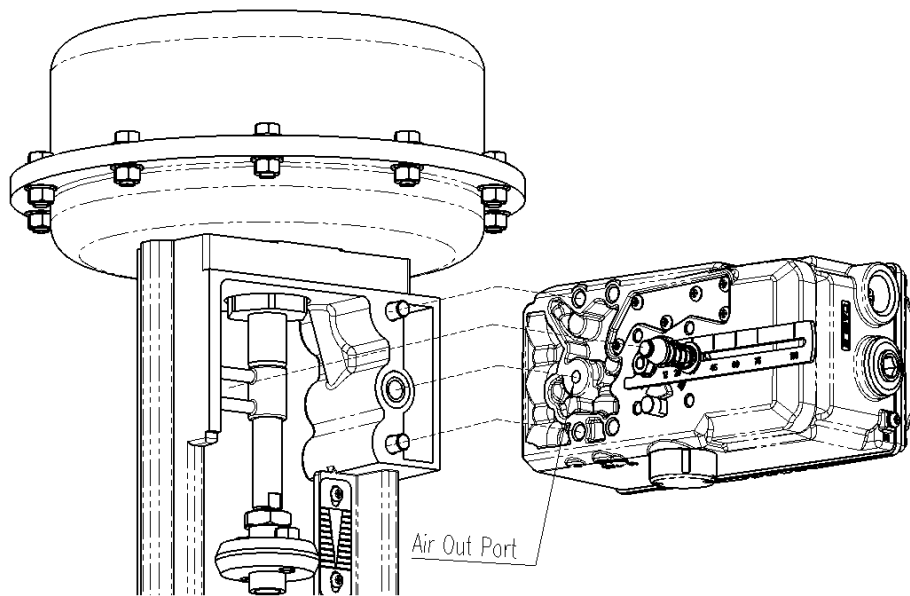

### 3.4 Figure 3303 and 3304 Installation

Figure 3303 and 3304 should be installed on rotary motion valve such as ball or butterfly type which uses rack and pinion, scotch yoke or other type of actuators which stem rotates 90 degrees. The following components are supplied in the quarter turn positioner kit:

- Positioner unit
  - Standard rotary bracket
  - 8 pcs x M6 hexagonal headed bolts
  - 4 pcs x M6 spring washer
  - ½" NPT gland for 6-8 mm cable diameter
- (Mounting bolts and washers to actuator, air connections and air hose to be supplied by customer)

#### 3.4.1 Bracket information

The bracket supplied standard with Figure 3303 and 3304 is made out of two components. The bracket is designed to fit onto the actuator with 20 mm stem height (H). If actuator stem height (H) is 30 mm or 50 mm, the bracket must be adjusted. Please refer to below table how to adjust the bracket.



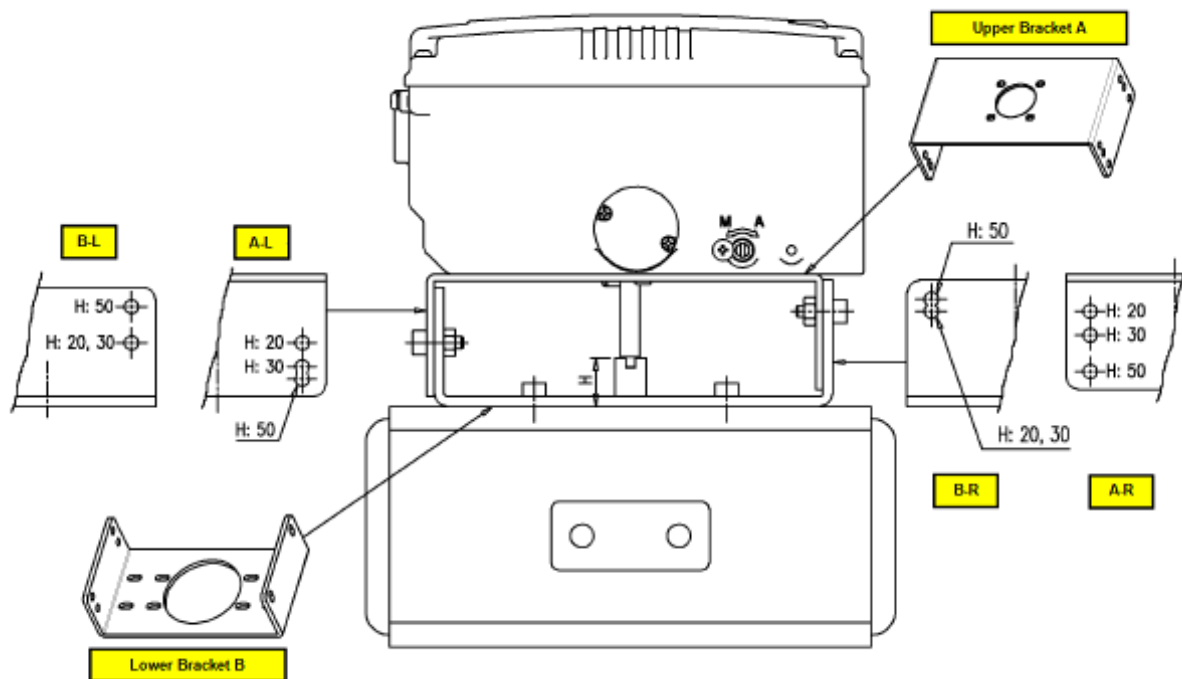

Actuator stem Height (H)	Markings of bolt holes	
	A-L & A-R	B-L & B-R
20 mm	H : 20	H : 20, 30
30 mm	H : 30	H : 20, 30
50 mm	H : 50	H : 50

Using hexagonal bolts and washer, fasten Figure 3303/3304 with the supplied bracket. Do not tighten bolts completely before correct mounting of Figure 3303/3304 has been confirmed. Insert Figure 3303/3304 main shaft into actuator's stem, and place the bracket align to the actuator's bolt holes. After the alignment, please fasten all of the bolts.

## 4 Connections

### 4.1 Safety

- Supply pressure should be clean and dry air – avoiding moisture, oil or dust.
- It is always recommended to use an air filter regulator.
- **The operation of this positioner has only been tested with clean air. For gases other than clean air please contact ERIKS for suitability.**

#### 4.2 Supply Pressure Condition

- Dry air with dew point at least 10°C lower than ambient temperature.
- Avoid dusty air. Use 5 micron or smaller filter.
- Avoid oil.
- Comply with ISO 8573-1 or ISA 7.0.01.
- Supply pressure range is 0.14~0.7 MPa (1.4~7 bar)
- Set air filter regulator's pressure level 10% higher than actuator's spring range pressure.



#### 4.3 Piping Condition

- Ensure inside of pipe is clean of obstructions.
- Do not use pipeline that is squeezed or shows any type of damages.
- Pipeline should have more than 6mm of inner diameter (10mm outer diameter) to maintain flow rate.
- The length of pipeline system should not be extremely long. Longer pipeline system may affect flow rate due to the friction inside of the pipeline.



#### 4.4 Connection – Actuator

##### 4.4.1 Single acting actuator – Figure 3301 & 3303

Single acting type positioner is set to use OUT1 port. OUT1 port of positioner should be connected with the supply pressure port of the actuator when using spring return actuator of single acting type.

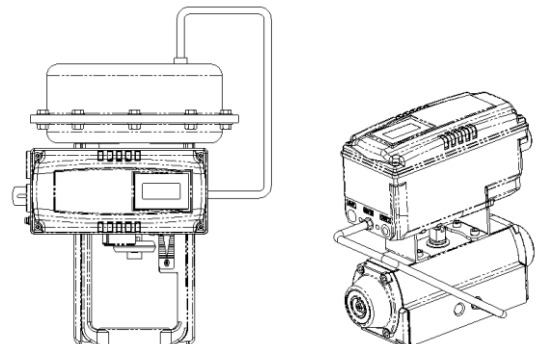

##### 4.4.2 Double acting actuator – Figure 3302 & 3304

Double acting type positioner is set to use OUT1 and OUT2 port. As input signal increases, the supply pressure will be supplied through OUT1 port.

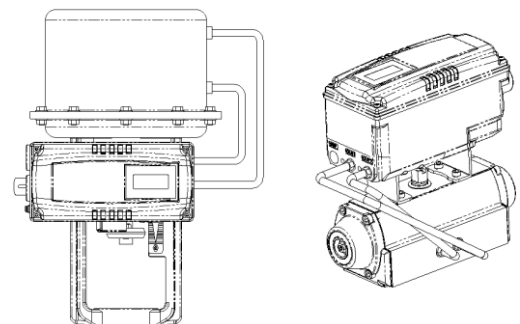

## 4.5 Connection – Power

### 4.5.1 Safety



- There are two conduit entries on the product.
- Before connecting terminal, ensure that the power is off completely. **Do not open the cover when the power is still alive.**
- Please use insulated electrical connection ring-type lug to protect against vibration or any other external impact.
- Positioner usually uses 4 ~ 20 mA DC. Minimum ampere of input signal of standard type positioner is 3.6 mA (NCS type) PTM internal type is 3.7 mA (NCS type) and HART or HART+PTM internal type is 3.8 mA but maximum ampere of input signal should be 24 mA or under.
- Compliance voltage of current source must be Min. 10 V and Max. 28 V. If the length of the supply cable between the current source and the positioner is long, or if there is a filter or safety barrier, then consider using a current source which could supply higher Compliance voltage.
- Positioner with PTM options must be supplied with with **9 ~ 28 V DC** separately.
- DO NOT connect Voltage source (9 ~ 28 V DC) to Input (4 ~ 20 mA DC) terminal (IN+, IN-) as it will cause PCB failure.
- Positioner should be grounded.
- Please use twisted cable with conductor section min. 1.25mm<sup>2</sup> and suitable for 600V (complying to the conductor table of NEC Article 310.) The outer diameter of the cable should be between 6.35 ~ 8 mm. Use shield wire to protect against electro-magnetic field and noise.
- Please ensure that keep away magnetic materials from a product. It may cause malfunction. For a magnetic screwdriver, It must be away more than 30 cm from the positioner.

### 4.5.2 Terminal Overview

#### Standard Terminals

Terminal name	Signal name	Function
IN+	Current input signal (+)	Apply analog current command 4 ~ 20 mA to this terminal to supply power and signal to the positioner.
IN-	Current input signal (-)	
F.G	Safety ground	Safety ground
OUT+	Analog output signal (+)	Analog feedback signal indicating the position of the current valve
OUT-	Analog output signal (-)	



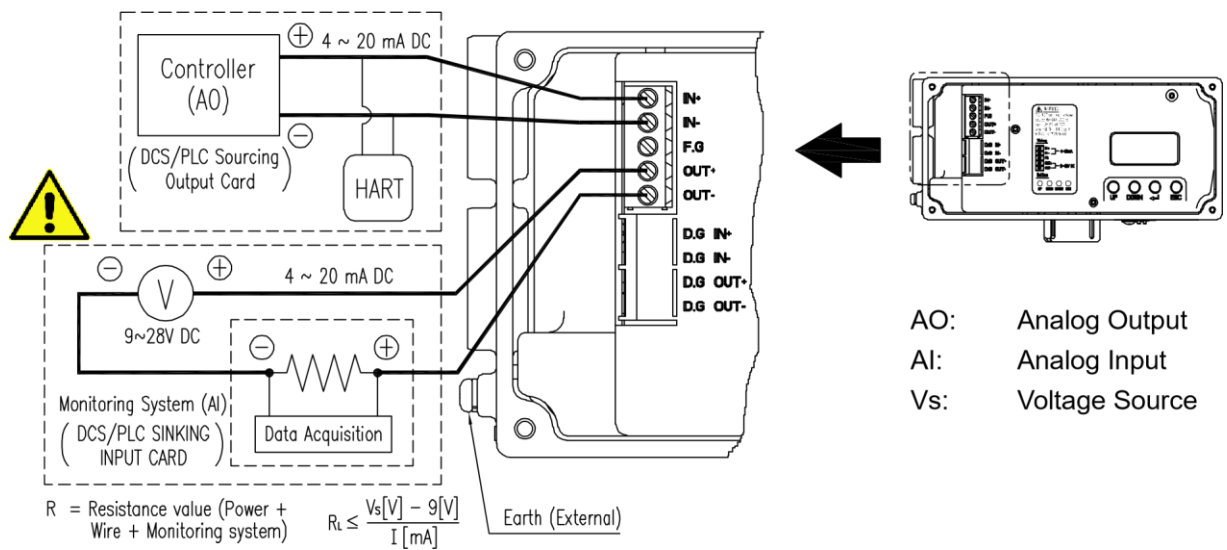

### 4.5.3 Ground

1. Ground connection must be done before operating the positioner.
2. Open base cover and there is an internal ground "F.G" on the left hand.  
An external ground bolt is located next to the conduit entry. Please make sure that the resistance is less than 100 ohm.
3. When using external ground, use (+) screw driver to unscrew the ground bolts. Insert outside ground bolts and spring washer into ring type terminal of the ground cables and tighten them with bolts.
4. When using internal ground, use 3 mm wrench to loosen locking bolts of the terminal box cover.

## 5 Adjustments

### 5.1 Auto/Manual Switch (A/M Switch)

Auto/Manual Switch allows the positioner to be functioned as by-pass. If switch is set as Auto, the positioner will operate per input signal. If switch is set as Manual, the positioner will send supply pressure directly to the actuator. It is important to check the allowed pressure level of the actuator when switch is loosened.

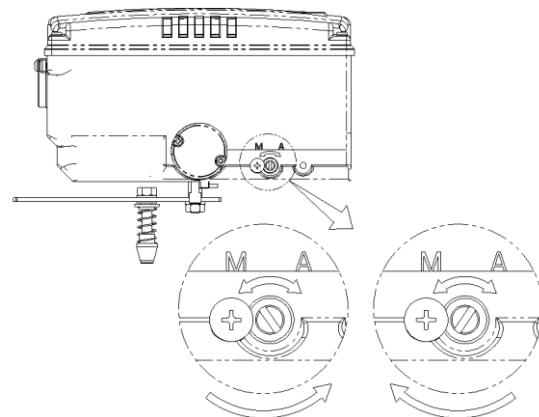

### 5.2 Variable Orifice Adjustment

Extremely small size of the actuator can cause hunting of the positioner. To adjust flow rate to the actuator, variable orifice can be inserted. The size of orifice is  $\varnothing$  1 mm. Please note that these orifices can only be used in conjunction with a gauge block. The orifices are supplied standard with the optional gauge block.

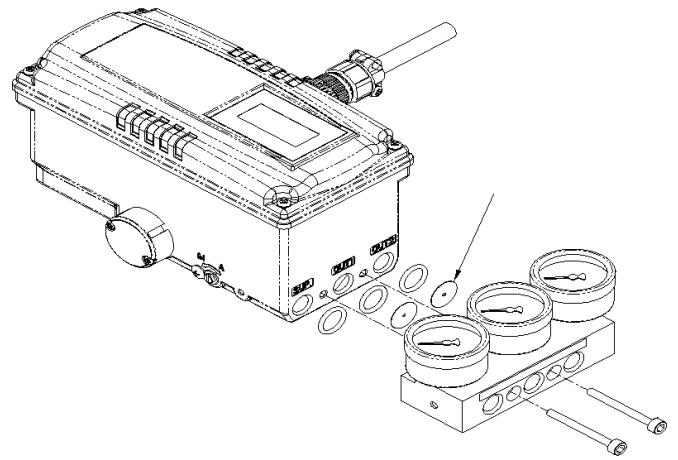

### 5.3 Option PCB Adjustment

By adding option sub-PCB, the positioner can be equipped with extra functions.

There are 2 types of sub-PCB's:

- Position Transmitter (PTM) only
- Position Transmitter (PTM) and HART<sup>®</sup> Protocol (HART)

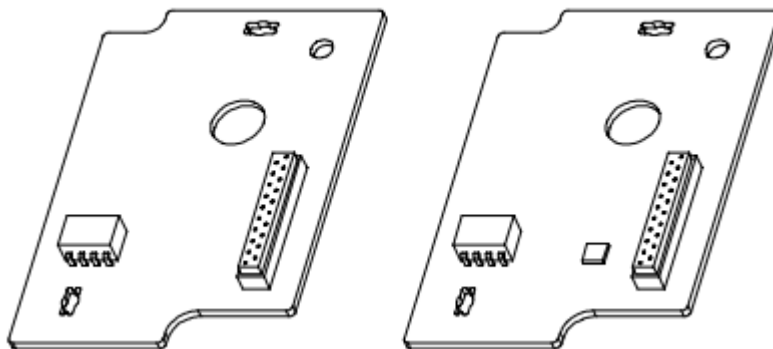

PTM only

PTM + HART

When purchasing option sub-PCBs separately, 4 Bolts and 2 supports are supplied together with subPCB

#### Installation Steps

- 1) Mount 2ea of sub-PCB support on sub-PCB with 2ea of bolt.
- 2) Open base cover, PCB cover. Separate the Main PCB from base body.
- 3) Insert connector of sub-PCB into connector of main PCB correctly.
- 4) Fasten sub-PCB with the rest of bolt 2ea.

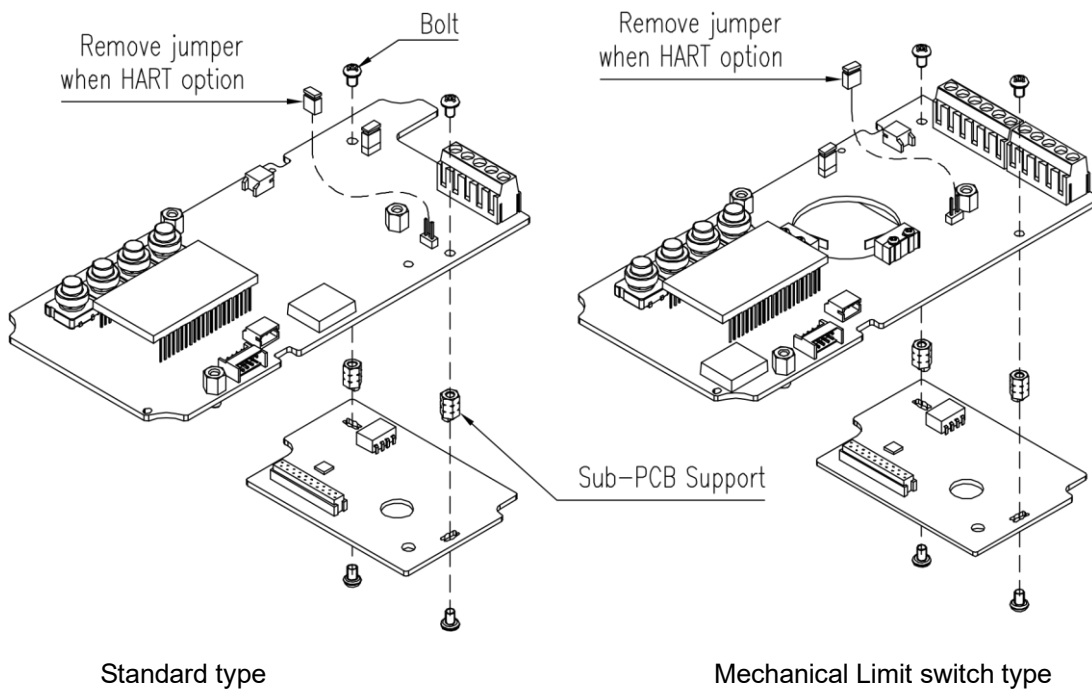

Installation of Option PCB on Main PCBs

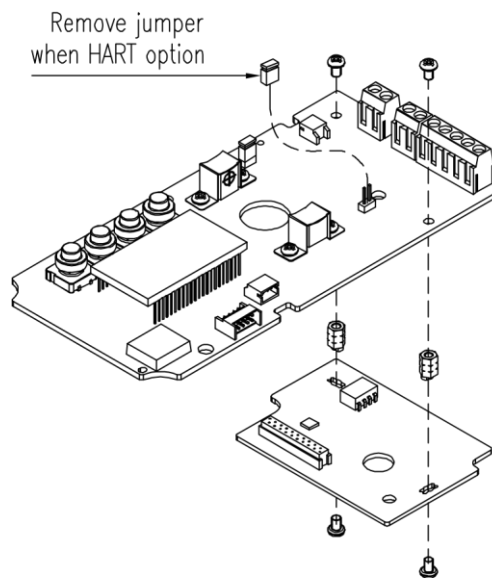

Inductive proximity limit switch type  
Installation of Option PCB on Main PCBs



**JP1 jumper must be removed, when HART option included sub-PCB is being mounted.**

- 5) After PTM sub-PCB is installed newly, values of PTM ZERO and PTM ENd must be calibrated for correct output signals. For the calibration of PTM ZERO and PTM ENd, please refer to section 6 of this manual.

## 6 Auto Calibration and PCB Operation

### 6.1.1 Warning



Following process will operate valve and actuator. Before proceeding with any Auto Calibration, please separate valve from the entire system by using bypass valve, so Auto Calibration will not affect entire valve process.

### 6.1.2 LCD display and buttons

#### 6.1.2.1 LCD display and symbols

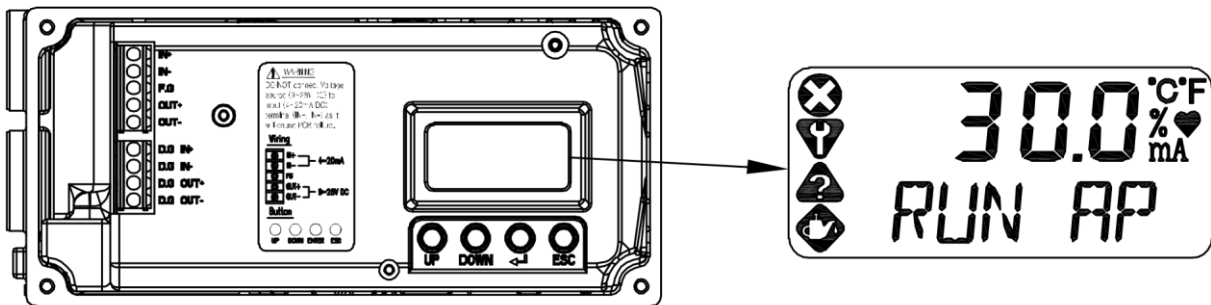

Fig 9-1

NE107 Symbols	Description	Symbols	Description
	Failure	°C	Degree in Celsius
	Functional Check	°F	Degree in Fahrenheit
	Out of Specifications	%	Percent
	Maintenance Required	♥	Communication status
		mA	Current in mA

The four symbols located on the left are the symbols that display alarm messages classified in four groups in accordance with NAMUR NE107. Assigning each alarm to a specific group of four groups can only be performed through EDD or DTM.

### 6.1.2.2 Button and function

Positioner has 4 buttons that perform various functions

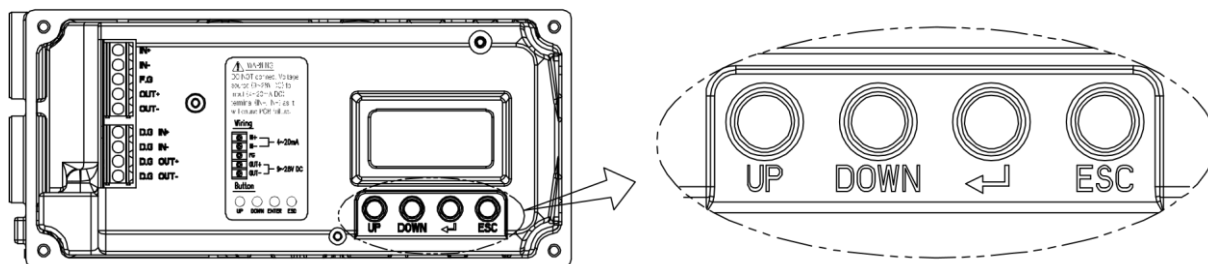
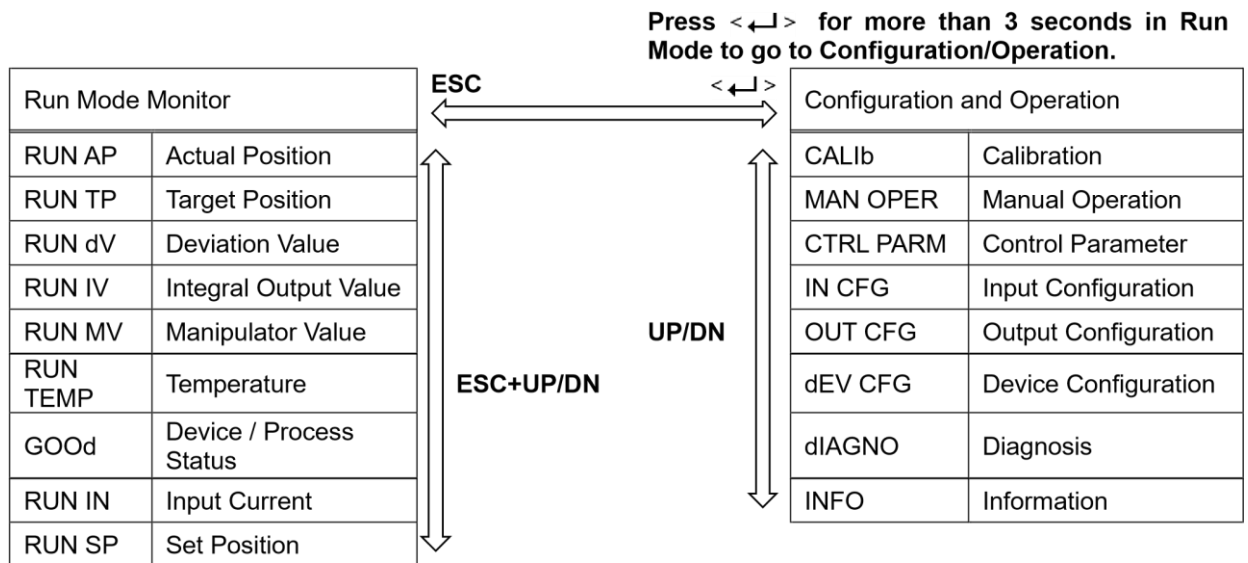

Fig 9-2

Buttons	Function
UP	Used to navigate to each menu at the same level or to increase the value of the selected parameter.
DOWN	Used to navigate to each menu at the same level in reverse order of UP button or to decrease the value of the selected parameter.
<↵> (ENTER)	Use to select the current menu or function, or to store the value of a modified parameter.
ESC	Used go directly to parent menu from current menu.

### 6.1.3 Menu levels

The basic menu structure consists of the RUN Mode Monitor and the Configuration/Operation. The Run Mode Monitor menu allows you to monitor the values of various variables. The Configuration/Operation menu provides calibration and tuning, manual operation, configuration of I/O port function, configuration and self-test of positioner, configuration of diagnostic function, and basic information of the positioner. See below for information on how to move between Run Mode Monitor menu and Configuration/Operation menu and how to move within Run Mode Monitor menu or Configuration and Operation.



Press the <↵> button to select the lower menu of the Configuration/Operation menu. Press the ESC button to return to parent menu after completing configuration. Pressing the ESC button anywhere in the menu structure several times returns the user to the uppermost menu, Run Mode Monitor menu.

#### 6.1.4 Run Mode (RUN)

The RUN Mode Monitor is displayed on the LCD display when power is provided to the positioner. Pressing the UP/DOWN button scrolls through the various process variables shown in table below. A "30.0 %" in the LCD display on the right indicates that the valve is in the 30 % position, and an "AP" indicates the abbreviation of "Actual Position".



The status variables displayed in the RUN Mode Monitor are divided into nine types as shown below.

On LCD	Name	Description
RUN AP [%]	Actual Position	Actual position of the valve indicated as %.
RUN TP [%]	Target Position	Target position in %
RUN dV [%]	Deviation Value	Deviation between target position and actual position.
RUN IV	Integral Output Value	Accumulated integral output value
RUN MV	Manipulator Value	Digital input value applied to I/P converter
RUN TEMP[°C]	Temperature	Internal temperature of positioner in °C.



** dS XXXX (PS XXXX)	**: Alarm Code  dS: Device Status PS: Process Status  XXXX: NE107 or Abbreviation of each alarm	The status of the current process or positioner is shown with English letter XXXX. Normally, GOOD is displayed when there is no problem, but alarm or status is displayed in abbreviated words (MNTR, FAIL, OUTS, FUNC and so on) along with NE107 symbol when a state change or alarm occurs. Any of the alarms is displayed alternately each time the ENTER button is pressed. (See 9.15 Status and Alarm Code)
RUN IN [mA]	Input Current	Current input signal in mA
RUN SP [%]	Set Position	Input signal converted into %

# When there is no alarm.



# When an alarm occurs.

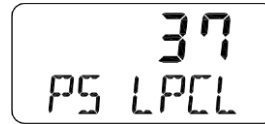

# Explaining contents of alarm display

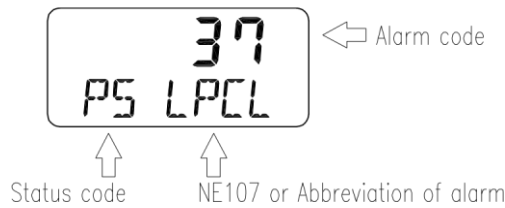

### 6.1.5 Configuration and Operation

The Table below shows the eight Configuration/Operation menus, each submenu, ranges for each parameter, and initial factory settings. The words shown in [ ] for each menu represent the abbreviations of each word displayed when operating the LCD screen.

Level 1	Level 2	Range	Initial factory setting
Calibration [CALIB]	Acting Type	[SINGLE, dOUBLE]	
	Auto Calibration 1 [AUTO 1]		
	Auto Calibration 2 [AUTO 2]		
	Travel Zero [TVL ZERO]		
	Travel End [TVL END]		
Manual Operation [MAN OPER]	Manual Operation by Set Position		

	[MAN SP]		
	Manual Operation by Manipulator Value [MAN MV]		
Control Parameters [CTL PARM]	Dead Band [dEAdbANd]	0.1 ~ 10.0 [%]	0.3 %
	Proportional Gain, Upward [KP UP]	0.1 ~ 50.0	1
	Proportional Gain, Downward [KP dN]	0.1 ~ 50.0	1
	Integral Gain, Upward [TI UP]	0.1 ~ 50.0	1
	Integral Gain, Downward [TI dN]	0.1 ~ 50.0	1
	Differential Gain, Upward [Kd UP]	0.1 ~ 50.0	1
	Differential Gain, Downward [Kd dN]	0.1 ~ 50.0	1
	Gap [GAP]	0.1 ~ 5.0 [%]	1 %
	GP [GP]	0.1 ~ 5.0	1
	GI [GI]	0.1 ~ 5.0	1
	GD [Gd]	0.1 ~ 5.0	1
	Auto Dead Band Mode [AUTO db]	oFF, [0%]	oFF
	Performance Mode [PER]	Stable, Normal, Fast [STbL, NORM, FAST]	NORM
	Input Configuration [IN CFG]	Signal Direction [SIG]	Normal, Reverse [NORM, REVS]
Split Range Mode [SPLIT]		4 ~ 20, 4 ~ 12, 12 ~ 20, Custom [4.20, 4.12, 12.20, CSt]	4.20
Custom Split Range Zero [CST ZERO]		4 ~ 20.0 mA]	4 mA
Custom Split Range End [CST ENd]		4 ~ 20.0 [mA]	20 mA

Level 1	Level 2	Range	Initial factory setting
Input Configuration [IN CFG]	Characterization [CHAR]	Linear, Quick Open, Equal Percent, User Set 5point, User Set 21point [LIN, QO, EQ, U5, U21]	LIN
	User Set Characterization 5p [USER 5P]	0 ~ 110[%]	0 %, 25 %, 50 %, 75 %, 100 %
	User Set Characterization 21p [USER 21P]	0 ~ 110[%]	0 %, 5 %, 10 %, ... 95 %, 100 %
	Tight Shut Open [TSHUT OP]	0 ~ 100 [%]	100.0 %
	Tight Shut Close [TSHUT CL]	0 ~ 100 [%]	0.3 %
	SP Ramp Up Rate [RAMP UP]	oFF, 0.1 ~ 100 [%]	oFF
	SP Ramp Down Rate [RAMP dN]	oFF, 0.1 ~ 100 [%]	oFF
Output Configuration [OUT CFG]	Position Transmitter Direction [PTM]	[NORM, REVS]	NORM
	Position Transmitter Zero [PTM ZERO]	0 ~ 100.00 [%]	
	Position Transmitter End [PTM END]	0 ~ 100.00 [%]	
	HART Feedback Direction [HT]	[NORM, REVS]	NORM
	Back Calculation [bACKCAL]	[oFF, on]	oFF
Device Configuration [dEV CFG]	Action [ACT]	[dIR, REVS]	REVS
	Linear Lever Type [LEVT]	[STd, AdP]	STd
	Linear Interpolation [ITP]	[oFF, on]	on with Linear oFF with Rotary
	Write Protect [W]	[UNLOCK, LOCK]	UNLOCK
	View Mode [VI]	[NORM, REVS]	NORM
	Polling Address [POL Addr]	[0 ~ 63]	0

	Factory Reset [dEFAULT]		
	Self-Test [SELFTEST]		
Diagnosis [dIAGNO]	Process Status [PS]	GOOd, FAIL, FUNC, OUTS, MNTR	GOOd
	Device Status [dS]	GOOd, Refer to 9.15 Status and Alarm Code.	GOOd
	View Monitoring Counts [VI CNTS]	[CYCL CNT, TVL ACUM, OPER CNT, FOP CNT, FCL CNT]	0
	Diagnosis Limit Configuration [LIMT CFG]	TVL HI, TVL LO, dV TIME, dV db, AL TVLH, AL TVLL,	100 %, 0 %, 10 sec, 5.0 %, oFF, oFF,
	Reset Alarm Status [RST ALRM]		

Level 1	Level 2	Range	Initial factory setting
Diagnosis [dIAGNO]	View Event Log [EVT LOG]	RECORd 0 - 19	0
	View PST Result Record [PST RSLT]	RECORd 1 - 10	bLANK
	PST Configuration [PST CFG]	INTERVAL, START PO, TOL, TARGET, HOLD TM, LIMT TM, PRAMP UP, PRAMP dN, NEXT PST	365 d, 100 %, 5 %, 90 %, 5 sec, 10 sec, 0 %, 0 %, oFF
	Run PST [PST NOW]		
	PST Schedule [PST SCHd]	on, oFF	oFF
Information	Model Name [YT3300*]		

[INFO]	Firmware Version [SOFT VER] Download Date	*.*.* YYYYMMDD	Program current version Program input date
	Run Time [RT]	*.*.* RT *d	
	Upward Stroke Time [FULL OP]	*.*.*	
	Downward Stroke Time [FULL CL]	*.*.*	
	Position Sensor Type [PSNT]	PTN, NCS	
	Absolute Position in Angle [AbS ANGL]	*.*.* °	
	HART Protocol Revision [HART VER]	7	7

The Table below identifies the range and initial factory settings of each parameter for Menu Level 2 and Menu Level 3 where the menu hierarchy has been lowered by one level.

Level 2	Level 3	Range	Initial factory setting
View Monitoring Counts [VI CNTS]	Cycle Count [CYCL CNT]	0 ~ 4,200,000,000	
	Travel Accumulated [TVL ACUM]	0 ~ 168,000,000 [%]	
	Operating Count [OPER CNT]	0 ~ 4,200,000,000	
	Full Open Count [FOP CNT]	0 ~ 4,200,000,000	
	Full Close Count [FCL CNT]	0 ~ 4,200,000,000	
LIMT CFG	Travel Hi Limit [TVL HI]	0 ~ 120 [%]	100 %
	Travel Lo Limit [TVL LO]	-10 ~ 50 [%]	0 %
	Travel Hi Limit Alarm Enable [AL TVLH]	oFF, on	oFF
	Travel Lo Limit Alarm Enable [AL TVLL]	oFF, on	oFF

Level 2	Level 3	Range	Initial factory setting
PST CFG	PST Interval [INTERVAL]	1 ~ 365 [days]	365

PST Starting Position [START PO]	0 ~ 100 [%]	100 %
PST Tolerance [TOL]	0.1 ~ 10 [%]	5 %
PST Target Position [TARGET]	0 ~ 100 [%]	90 %
PST Hold Time [HOLD TM]	1 ~ 60 [sec]	5 sec
PST Limit Time [LIMT TM]	1 ~ 300 [sec]	10 sec
PST Ramp Up Rate [PRAMP UP]	oFF, 1 ~ 100 [%/sec]	oFF
PST Ramp Down Rate [PRAMP dN]	oFF, 1 ~ 100 [%/sec]	oFF
PST Time Remaining [NEXT PST]	oFF, 1 ~ 365 [days], 0 ~ 24 [hour]	oFF

### 6.1.6 Calibration (CALib)

The calibration consists of five menus.

Calibration [CALib]	Acting Type [SINGLE/ dOUbLE]	Set manually single or double acting by actuator type
	Auto Calibration 1 [AUTO 1]	Calibration on the zero and end points of the valve
	Auto Calibration 2 [AUTO 2]	Calibration on all parameters required to operate the valve
	Travel Zero [TVL ZERO]	Manually adjust the zero point of the valve
	Travel End [TVL ENd]	Manually adjust the endpoint of the valve

Auto Calibration simplifies calibration without having to go through complex gain tuning. Once the current input between 4 and 20 mA is applied, it takes approximately 2-3 minutes to complete the automatic calibration, which may vary depending on the size of the actuator. There are two types of Auto Calibrations as shown below so that you select and use them as required.

	ZERO	END	P, I, D gain	RA, DA	BIAS
AUTO 1	O	O	X	X	X
AUTO 2	O	O	O	O	O

### 6.1.6.1 Acting Type (SINGLE / dDOUBLE)

This is used to change the settings of the positioner to SINGLE or dDOUBLE, depending on the actuator type. The setting of the SINGLE and dDOUBLE affects the automatic calibration, so it must be set carefully considering the actuator type.



**If the actual acting type of Actuator is different from the set value, it will cause a problem, so make sure that the actual acting type matches the set value.**



Press <UP> or <DOWN> button if the above is not displayed.

Press <UP> or <DOWN> button if the above is not displayed.

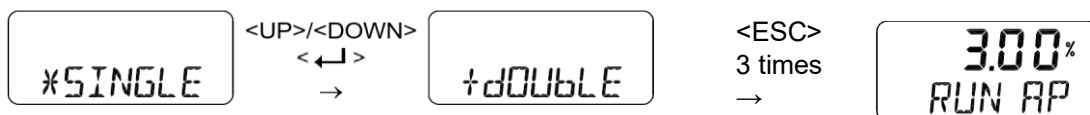

### 6.1.6.2. Auto Calibration 1 (AUTO 1)

AUTO 1 is used to set only the origin and end points. It does not change the PID and other parameter values that already have been set. This is usually used when the origin and end points of the already calibrated positioner have changed slightly.

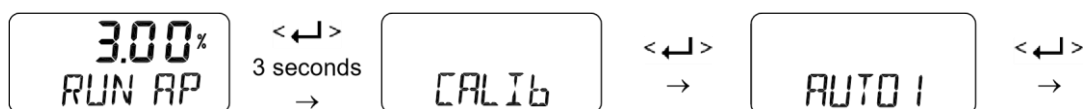

Press <UP> or <DOWN> button if the above is not displayed.

Press <UP> or <DOWN> button if the above is not displayed.

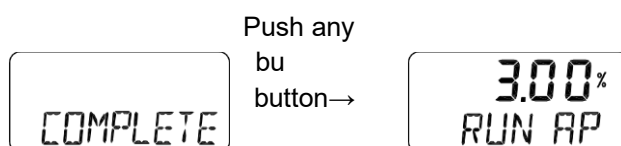

### 6.1.6.3. Auto Calibration 2 (AUTO 2)

AUTO 2 tunes up and then changes all parameters required for valve operation. Be sure to perform this AUTO 2 when installing the positioner on the valve for the first time or when reinstalling the positioner from the actuator.

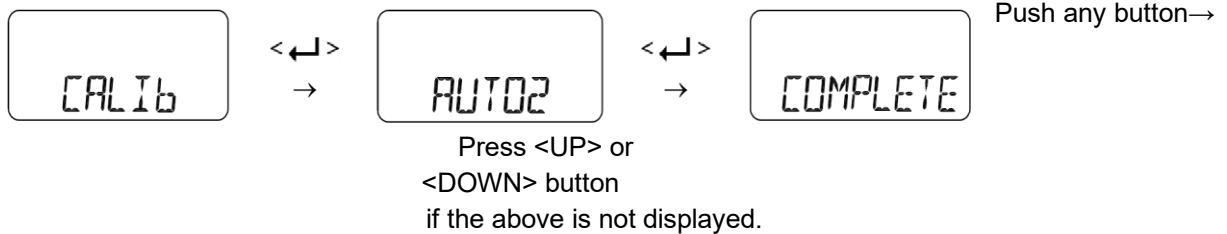

#### Travel Zero (TVL ZERO) and Travel end (TVL END)

This is a manual adjustment of the zero point or endpoint of the valve after auto calibration. Once you enter the TVL ZERO (or TVL END) setting, press the UP/DOWN button to change the zero point (or endpoint) of the valve, and then press the ENTER button to save it. The saved position is recognized as the zero (or endpoint) of the valve.

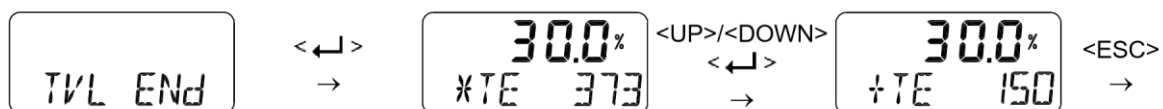
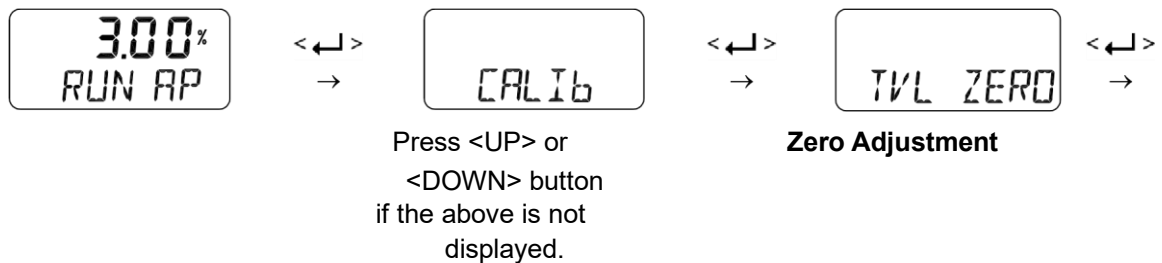

End Adjustment

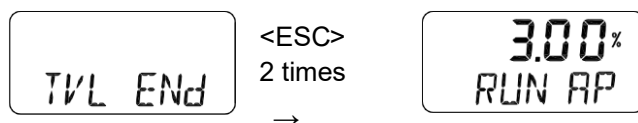



## 6.2 Manual Operation (MAN OPER)

It is used to manually raise or lower the valve stem by operating the UP or DOWN buttons. This can be used to observe the move of valve stem without any external input signals. When engaged, the current input signal to the positioner has no effect on the positioner.



**Manual operation may affect the process in service, so use this function when the process is down or when it is acceptable to shut down the process.**

### 6.2.1 Manual Operation by Set position (MAN SP)

The target position is incremented by the UP and DOWN buttons based on the currently entered set position values, which moves the stem of the valve up and down. Once out of the menu by <ESC>, the positioner is controlled again by an input signal.

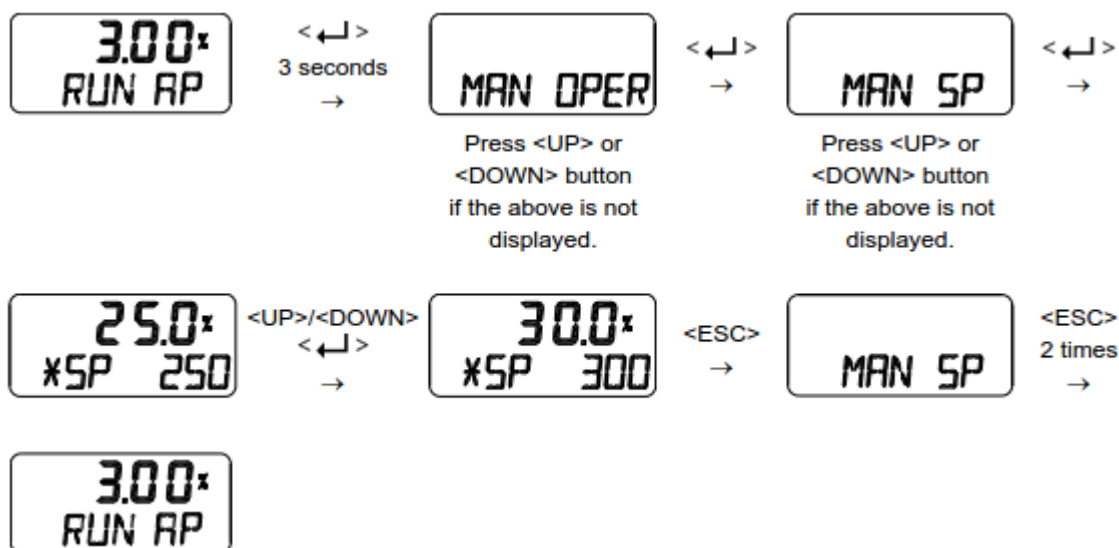

### 6.2.2 Manual Operation by Manipulator Value (MAN MV)

The input to I/P converter is incremented or decremented by the UP and DOWN buttons based on the currently entered I/P input value, which moves the stem of the valve up and down. Once out of the menu by <ESC>, the positioner is controlled again by an input signal.

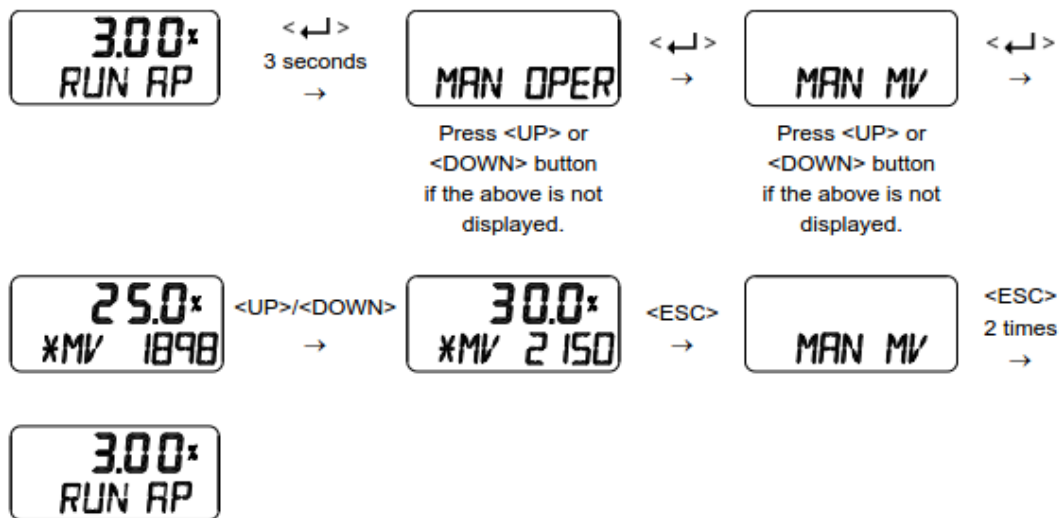

### 6.3 Control Parameters (CTL PARM)

Followings are the values changeable at the Control Parameters Mode.

- 1) Dead Band (dEAdbANd)
- 2) Forward P parameter (KP UP) and reverse P parameter (KP dN)
- 3) Forward Integral time parameter (TI UP) and reverse Integral time parameter (TI dN)
- 4) Forward D parameter (Kd UP) and reverse D parameter (Kd dN)
- 5) GAP Parameter (GAP)
- 6) GAP P Parameter (GP)
- 7) GAP I Parameter (GI)
- 8) GAP D Parameter (Gd)
- 9) Auto Dead band Mode (AUTO db)
- 10) Performance Mode (PER)

#### 6.3.1 Dead Band (dEAdbANd)

Deadband indicates the size of the allowable deviation that is set near the target position. If the valve has large packing friction, this value can be adjusted and set accordingly to prevent the limit cycle caused by the friction. If the deadband is set to 0.5 %, its range is  $\pm 0.5$  % of the target.

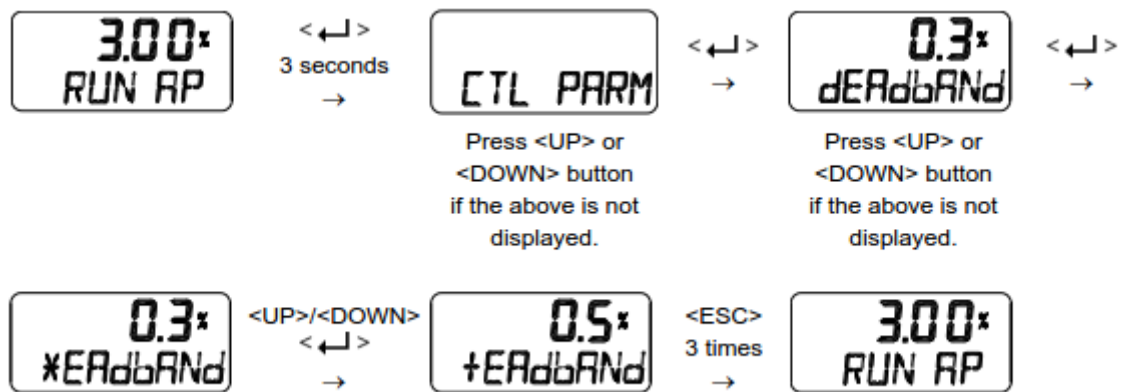

### 6.3.2 Forward P parameter (KP UP) and reverse P parameter (KP dN)

The KP parameter is the proportional control constant to the calibration signal to reduce the error between the target position and the current position, the KP UP is applied when the valve moves in the direction of increasing output air pressure, and KP dN is applied when the valve moves in the direction of venting output air pressure. A larger value of gains "KP UP" or "KP dN" moves the valve faster to reach a target position, but the valve tends to oscillate if set to high. In contrast, smaller gains improve stability, but make it slower to reach a target position.

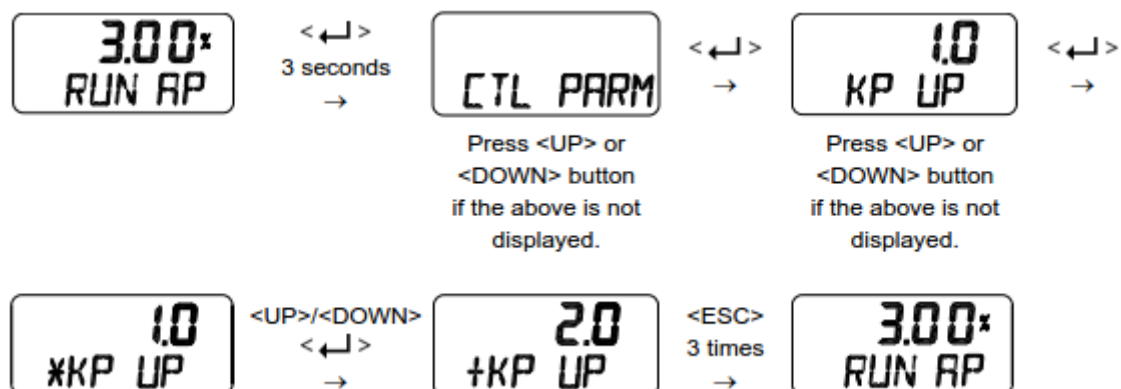

### 6.3.3 Forward Integral time parameter (TI UP) and reverse Integral time parameter (TI dN)

TI parameters are an integral value that add the error correction signal to the existing calibration signal, TI UP is applied when the valve moves in the direction of increasing the output air pressure, and TI dN is applied when the valve moves in the direction of decreasing the output air pressure. A smaller TI makes the valve faster to reach a target position and tends to cause oscillation.

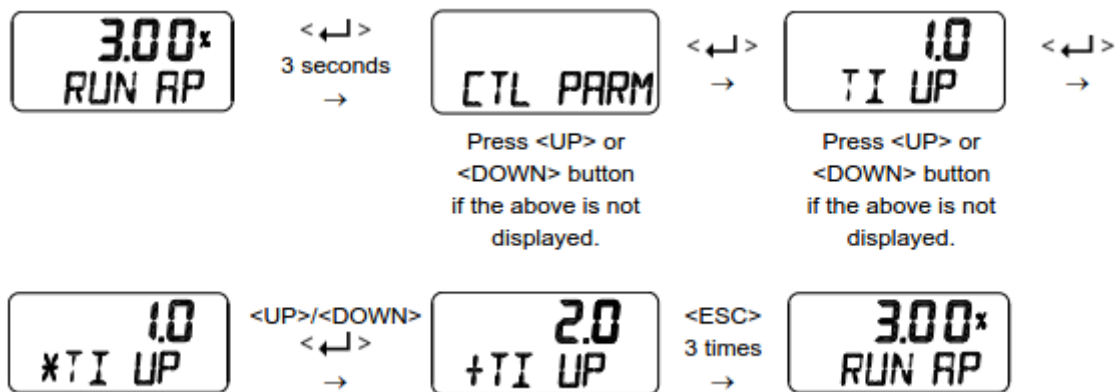

### 6.3.4 Forward D parameter (Kd UP) and reverse D parameter (Kd dN)

The Kd parameter is a differential value that adds the correction signal due to the rate of error to the existing calibration signal. Kd UP is applied when the valve moves in the direction of increasing output air pressure, and Kd dN is applied when the valve moves in the direction of decreasing output air pressure. A larger D value makes the valve hunting easier, and a smaller value can lead to poor linearity or dynamic properties.

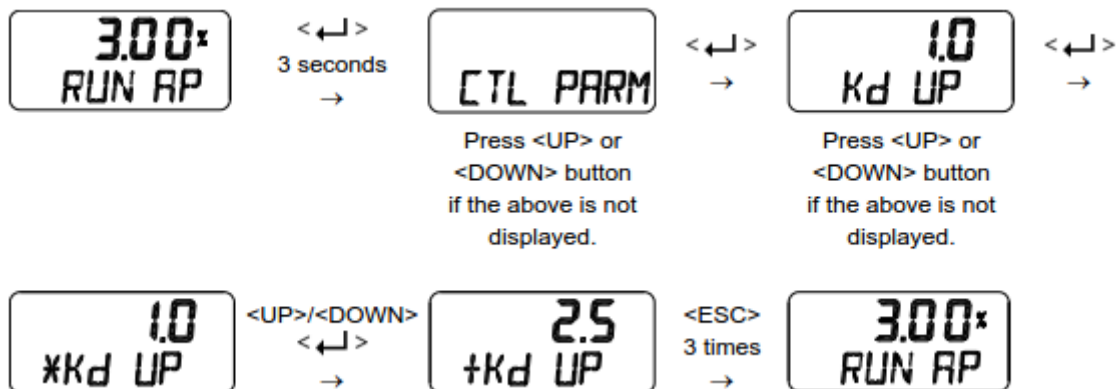

### 6.3.5 GAP Parameter (GAP)

The GAP parameter sets the control range at which Gap control begins. If the current position of the valve falls within the setting range GAP (%) relative to the final target position (target position  $\pm$  GAP), Gap control operates along with PID Control. When the GAP control begins, the PID GAP parameters (GAP P, GAP I and GAP D) interacted with the PID parameters (KP, KI and KD) are applied to valve control.

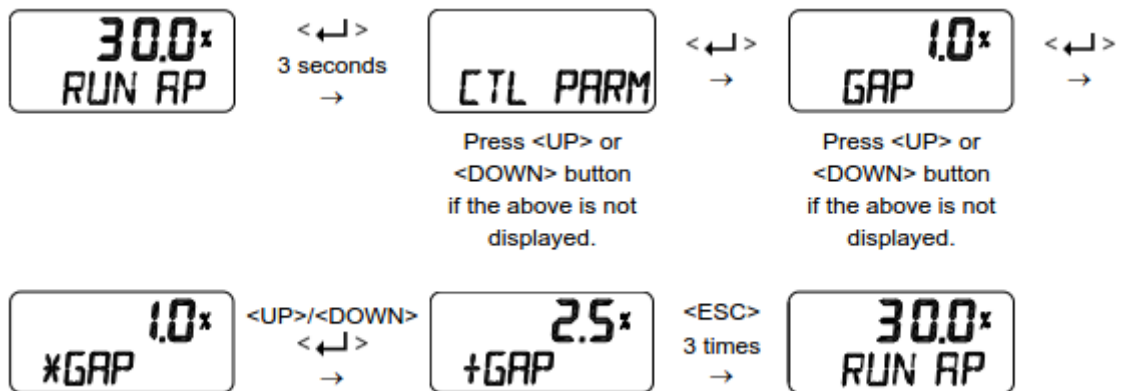

### 6.3.6 GAP P parameter (GP)

GP is a proportional gain. If the valve position is within the GAP parameter range, a proportion gain created based on KP and GP is applied to valve control.

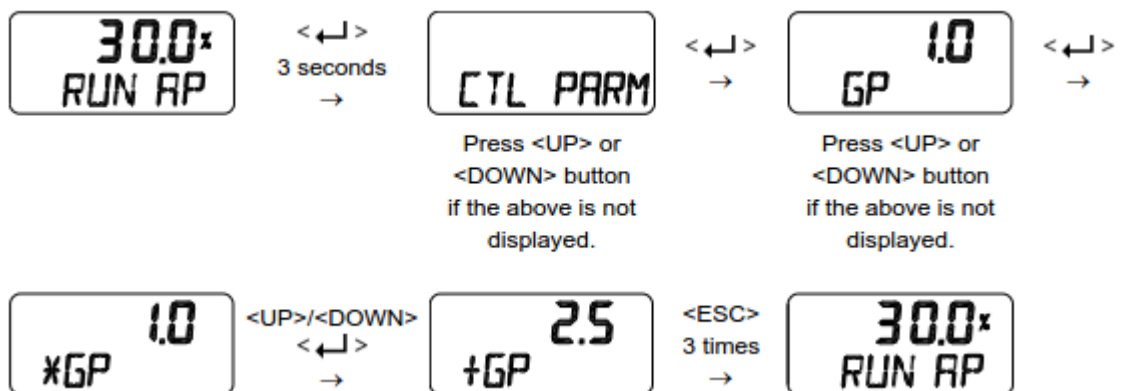

### 6.3.7 GAP I parameter (GI)

GI is an integral gain. If the valve position is within the GAP parameter range, an integral gain created based on 1/TI and GI is applied to valve control.

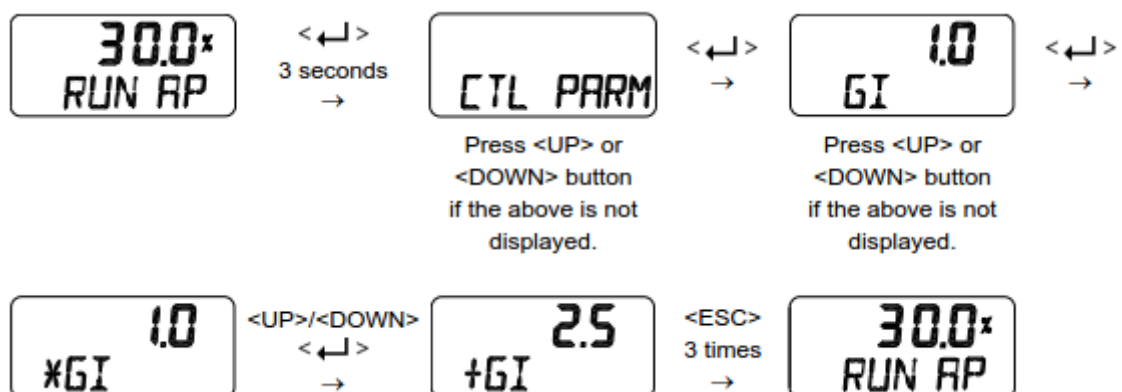

### 6.3.8 GAP D parameter (Gd)

Gd is a differential gain. If the valve position is within the GAP parameter range, a differential gain created based on Kd and Gd is applied to valve control.

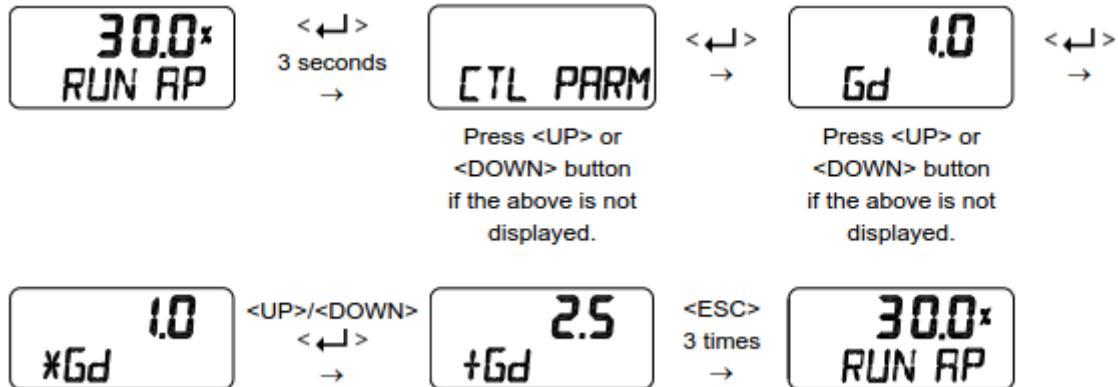

### 6.3.9 Auto Dead band Mode (AUTO db)

This function is used to suppress a hunting for valves with high static friction. The initial value is OFF and it shall be set to 0 % to activate the auto dead band automatically. The value is changed to a proper value once this mode is activated.

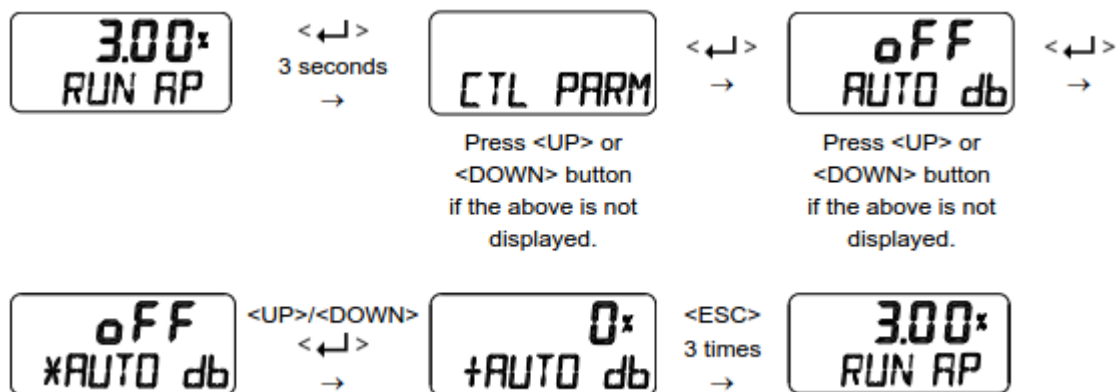

### 6.3.10 Performance Mode (PER)

This mode has three modes of operation: Stable, Normal, and Fast that allow you to select the required responsiveness. The performance modes indicate the response characteristics from slow response to quick response in the order of Stable, Normal and Fast.

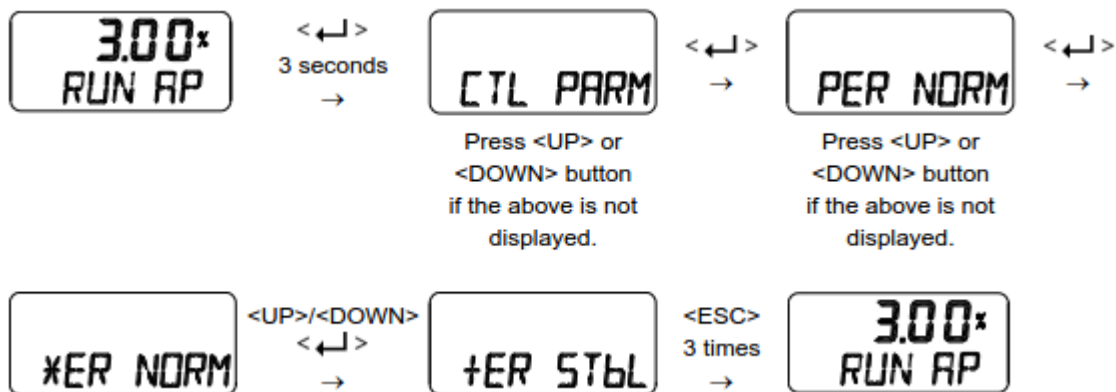

## 6.4 Input Configuration (IN CFG)

Followings are the values changeable at the Input Configuration Mode.

- 1) Signal Direction (SIG NORM / REVS)
- 2) Split Range Mode (SPLIT)
- 3) Custom Split Range Zero (CST ZERO)
- 4) Custom Split Range End (CST END)
- 5) Characterization Curves (CHAR)
- 6) User Set Characterization 5 Points (U5)
- 7) User Set Characterization 21 Points (U21)
- 8) Tight Shut Open (TSHUT OP)
- 9) Tight Shut Close (TSHUT CL)
- 10) Target Position Ramp Up Rate (RAMP UP) and Target Position Ramp Down Rate (RAMP dN)

### 6.4.1 Signal Direction (SIG NORM / REVS)

This function changes the action type of the valve, NORM or REVS. If NORM is selected, the air is completely released through output port 1 of the positioner when 4 mA is applied, and the maximum air pressure is loaded to the actuator through output port 1 when 20 mA is applied. If set to REVS, the maximum air pressure is loaded to the actuator via output port 1 when an input current of 4 mA is applied to the positioner.

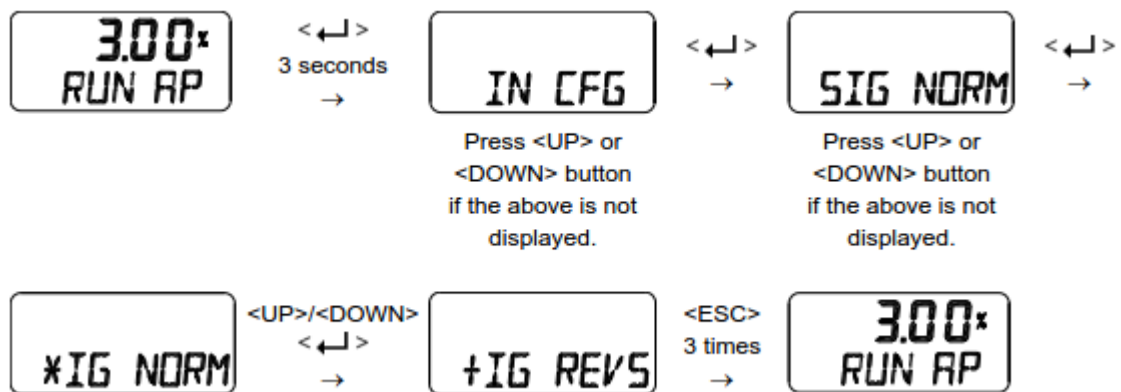

#### 6.4.2 Split Range Mode (SPLIT)

This is used to set the range of the input signal to control the entire stroke of the valve. You can select one of the four input signals that consists of 4 ~ 20 mA, 4 ~ 12 mA, 12 ~ 20 mA, and user settings (Custom, CSt). 4 ~ 20 mA is the factory setting.

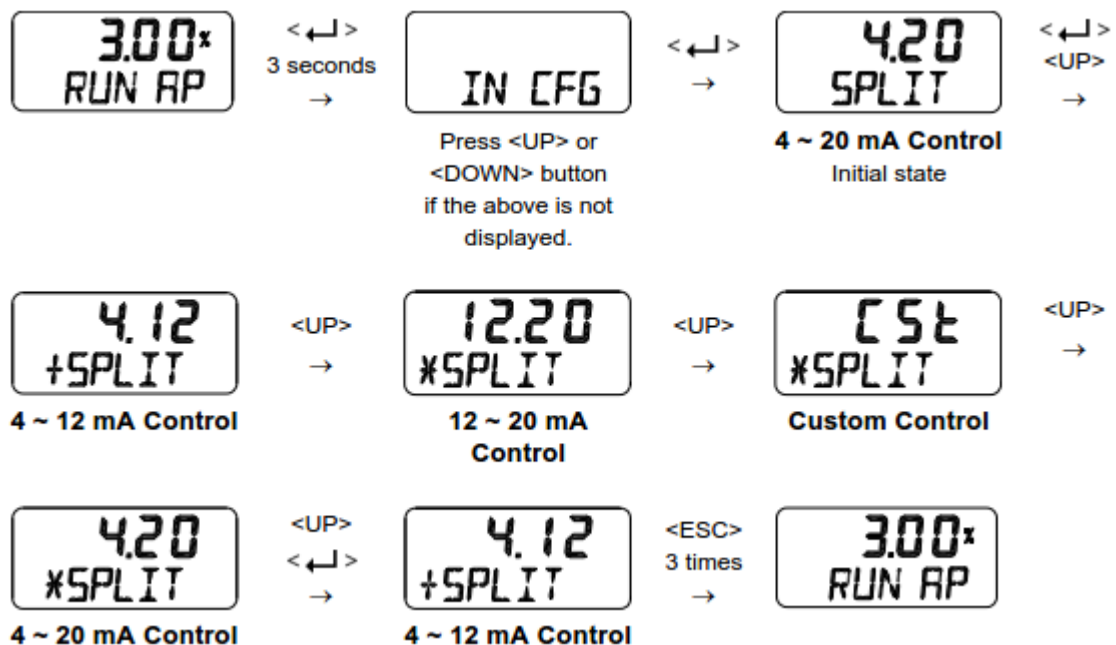

#### 6.4.3 Custom Split Range Zero (CST ZERO)

It is used to set the current corresponding to the zeropoint when the valve position of 0 to 100 % is controlled by the user-set CUSTOM. For example, if the valve is controlled by 6 ~ 20 mA instead of 4 ~ 20 mA, CST ZERO is 6 mA. However, the difference of the current between the origin point and the endpoint must be greater than 4 mA.



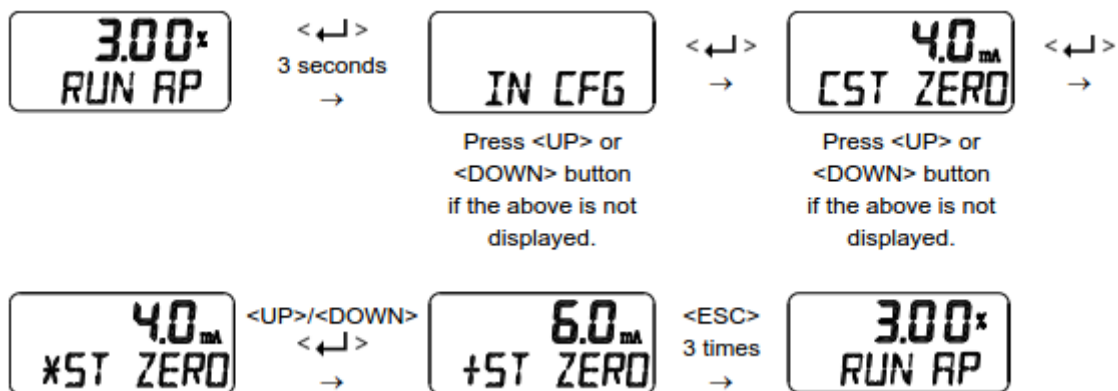

This function is activated by saving the Split Range Mode (SPLIT) of above Section 9.9.2 as “CSt”.

#### 6.4.4 Custom Split Range End (CST END)

It is used to set the current corresponding to the endpoint when the valve position of 0 to 100 % is controlled by the user-set CUSTOM. For example, if the valve is controlled by 4 ~ 18 mA instead of 4 ~ 20 mA, CST END is 18 mA. However, the difference of the current between the origin point and the endpoint must be greater than 4 mA.

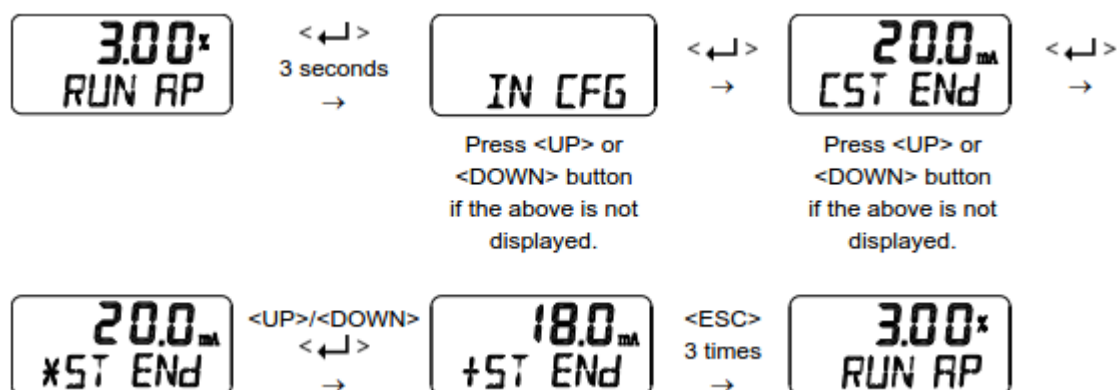

This function is activated by saving the Split Range Mode (SPLIT) of above Section 9.9.2 as “CSt”.

#### 6.4.5 Valve Flow Characterization Curves (CHAR)

The flow characteristic curve of valve is available by selecting one of the following: Linear(LIN), Quick Open(QO), Equal Percentage(EQ), User Set Characterization 5 Points (U5) and User Set Characterization 21 Points (U21).

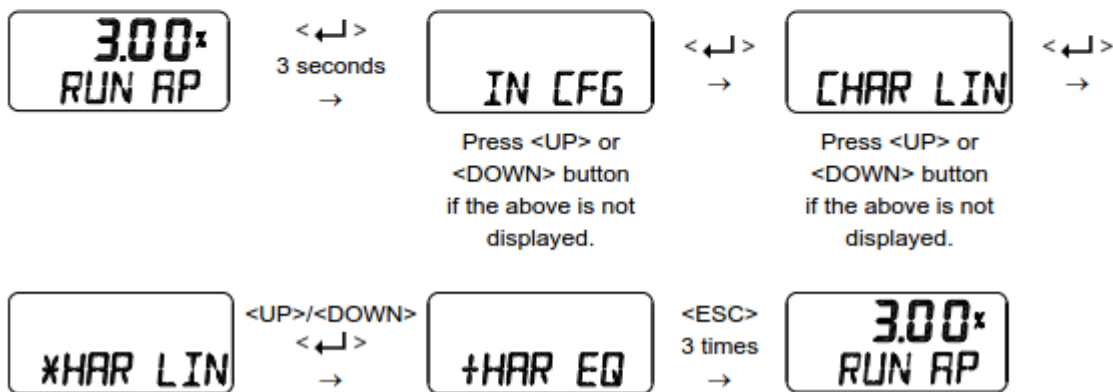
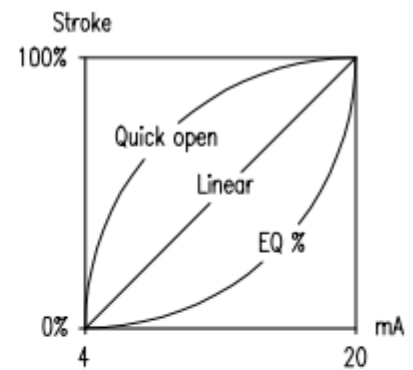

#### 6.4.6 User Set Characterization 5 Points (U5)

A total of 5 target positions are set every 4 mA intervals. When shipped from the factory, the initial positions are P0 (4 mA, 0 %), P1 (8 mA, 25 %), P2 (12 mA, 50 %), P3 (16 mA, 75 %), and P4 (20 mA, 100 %). User can change all 5 points or only change partially and exit the menu by pressing **<ESC>** button.

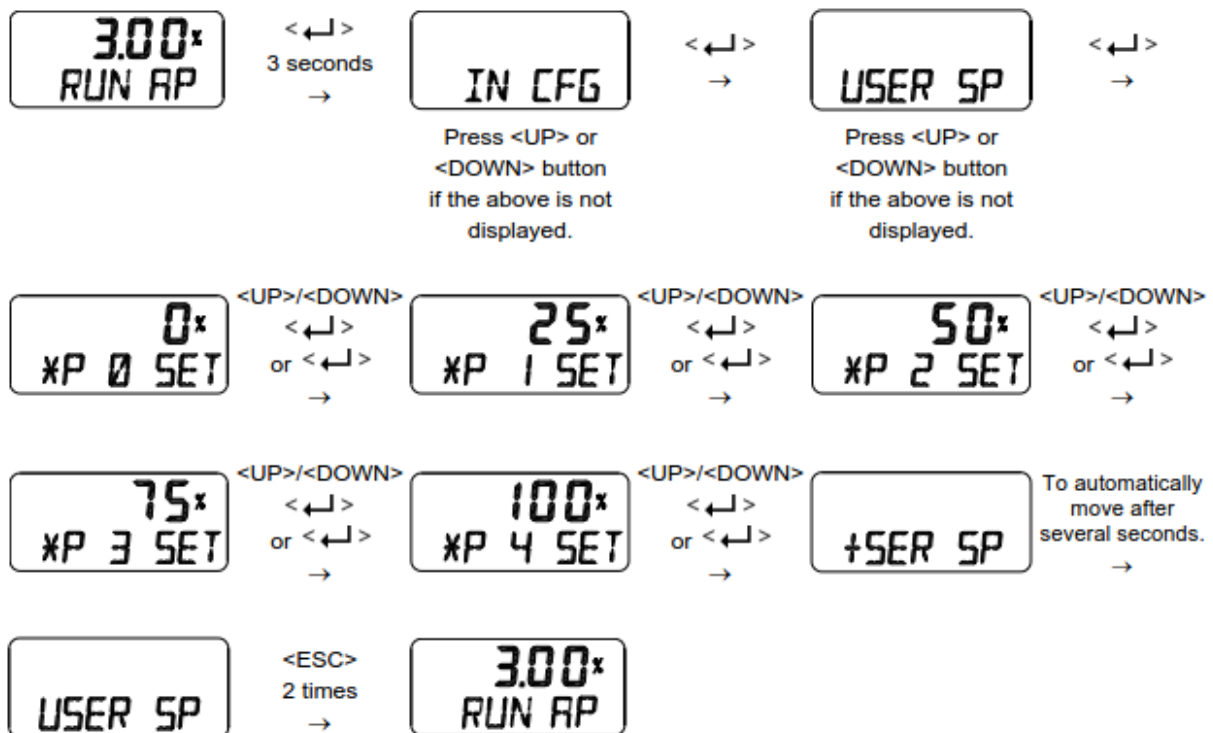

This function is activated by saving the Valve Flow Characterization Curves (CHAR) of above Section

**6.4.6 as “U5”.**

**6.4.7 User Set Characterization 21 Points (U21)**

A total of 21 target points can be set every 0.8 mA intervals. When shipped from the factory, the initial P0 (4 mA, 0 %), P1 (4.8 mA, 5 %), P2 (5.6 mA 10 %), - - -, P19 (19.2 mA, 95 %), and P20 (20 mA, 100 %).

For example, a characteristic curve below can be made through the settings of P1 to P20.

User can change all 21 points or only change partially and exit the menu by pressing <ESC> button.

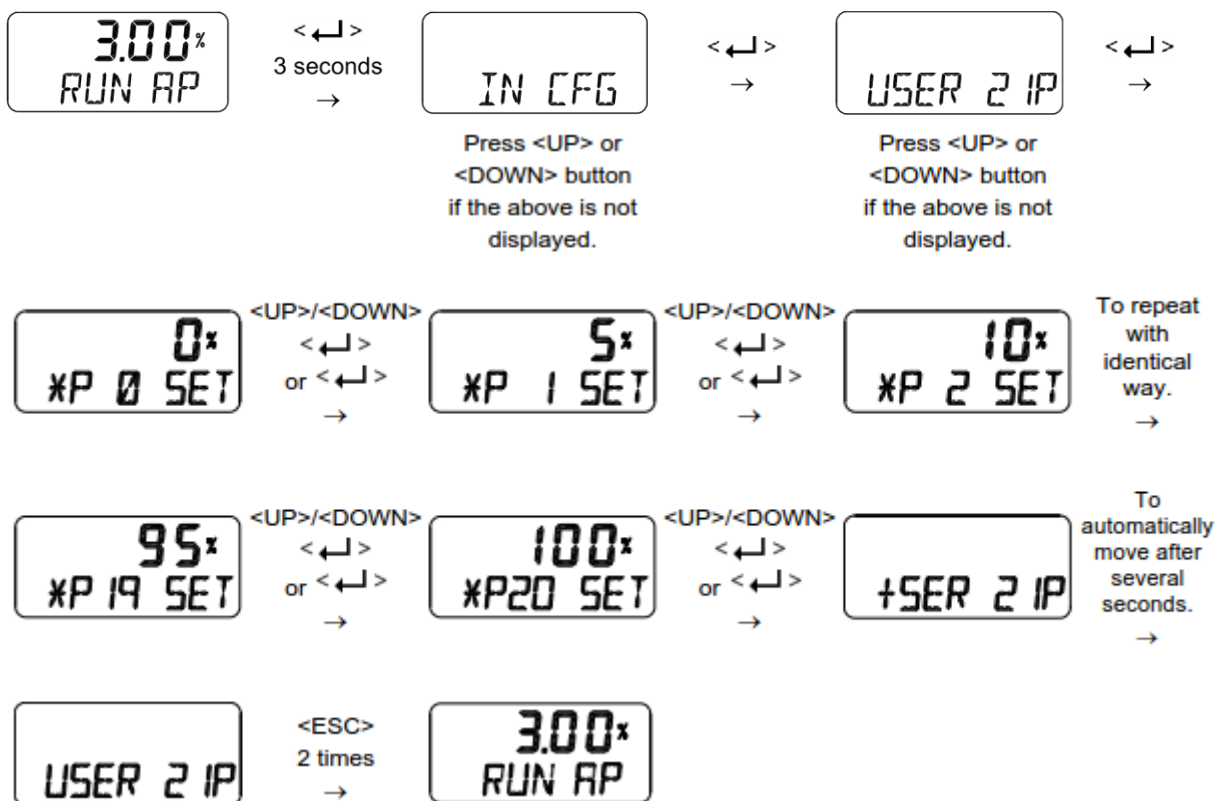
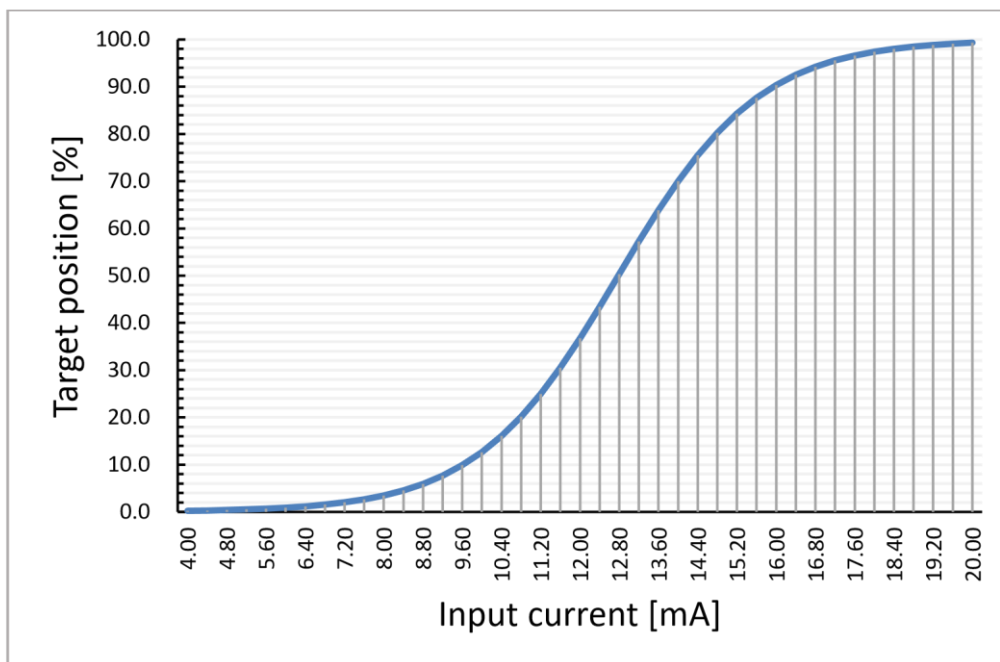

This function is activated by saving the Valve Flow Characterization Curves (CHAR) of above Section

**6.4.7** as “U21”.

### 6.4.8 Tight Shut Open (TSHUT OP)

It is used to ensure that the valve is fully opened with a large force. When the input signal SP is greater

than the value set in the TSHUT OP, all available force is applied to OUT 1 port to tightly open the valve. If the input current of 4 mA is 0% of valve position and 20 mA is 100% of valve position, and the Tight Shut Open value is set to any position less than 100 % (e.g. 95 %), then the valve stroke will be 100 % immediately when the input signal is over the set value (e.g. 95 %). A full supply pressure applied to the actuator via the OUT1 port prevents leakage of the valve by shutting the valve tightly. However, when the value is set to 100 %, Tight Shut Open function doesn't work.

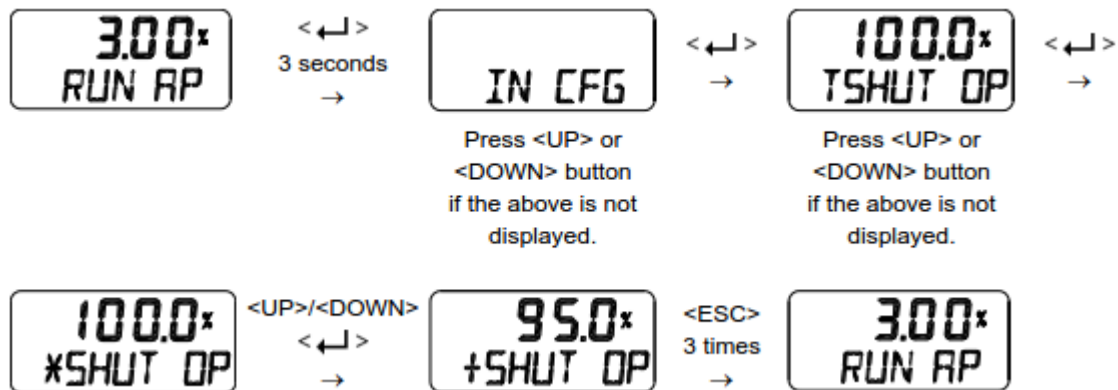

### 6.4.9 Tight Shut Close (TSHUT CL)

It is used to ensure that the valve is fully closed with a large force. When the input signal SP is smaller than the value set in the TSHUT CL, air pressure is vented through OUT 1 port to tightly close the valve. If the input current of 4 mA is 0 % of valve position and 20 mA is 100 % of valve position, and the Tight Shut Close value is set to any position larger than 0 % (e.g. 5 %), then the valve stroke will be 0 % immediately when the input signal goes below the set value (e.g. 5 %). The air venting from the actuator via the OUT1 port prevents leakage of the valve by shutting the valve tightly. However, when the value is set to 0 %, Tight Shut Close function doesn't work.

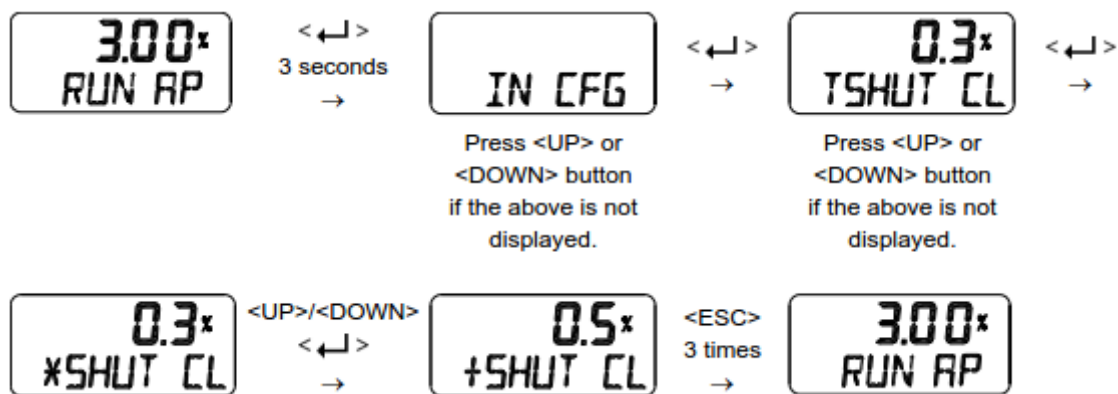

The following graph shows the operation of the valve stroke when the input signal corresponding to Tight Shut Open or Tight Shut Close is applied to the device.

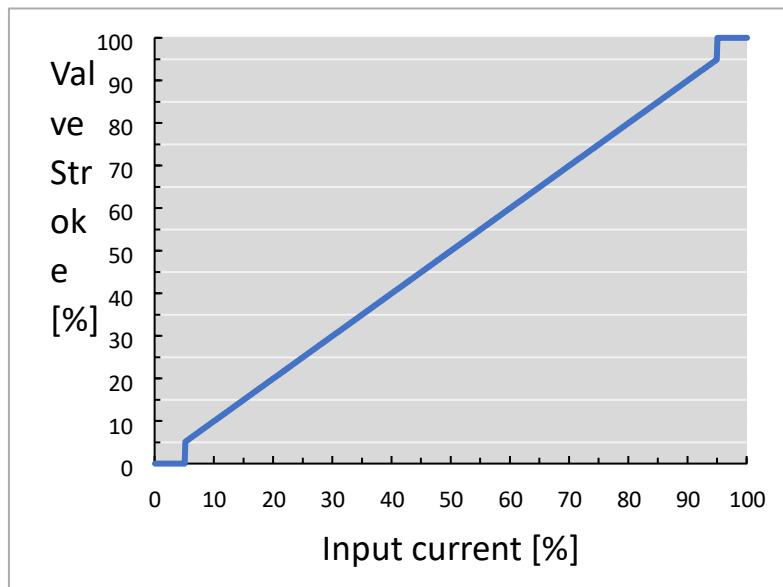

### 6.4.10 Target Position Ramp Up Rate (RAMP UP) and Target Position Ramp Down Rate (RAMP dN)

It is used to prevent the valve from moving too fast when the process to be controlled is too sensitive to rapid changes in flow or pressure. The unit of setting is %/sec. If you want to move 100 % of the stroke for about 5 seconds, set it to 20 [%/sec]. The rising and falling speed can be set independently, and the valve will move to the target position as soon as possible when this function is switched off.

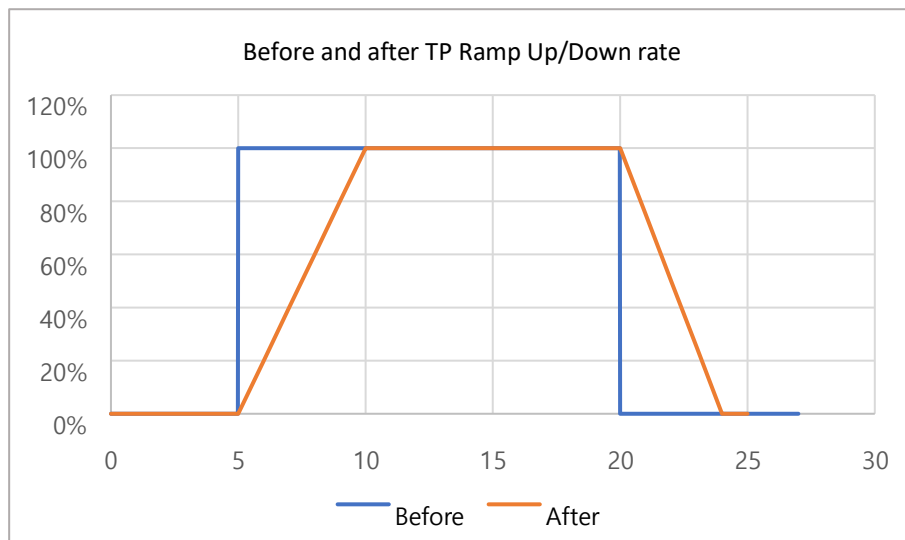

The curves below show the target position (red) and the actual position (blue) of the valve after applying SP Ramp Up/Down rate.

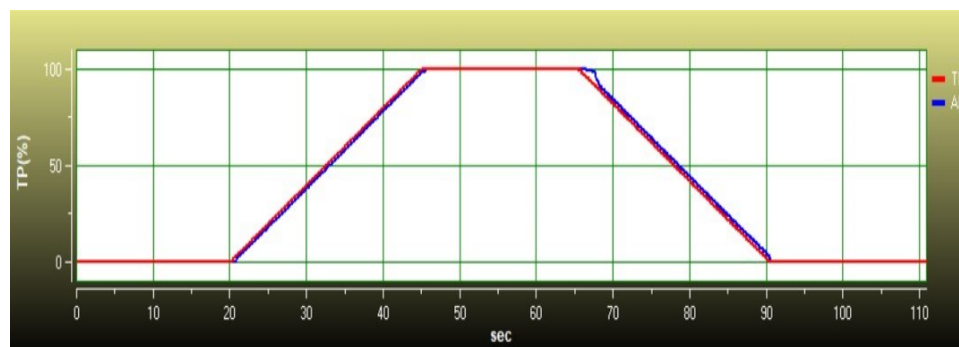

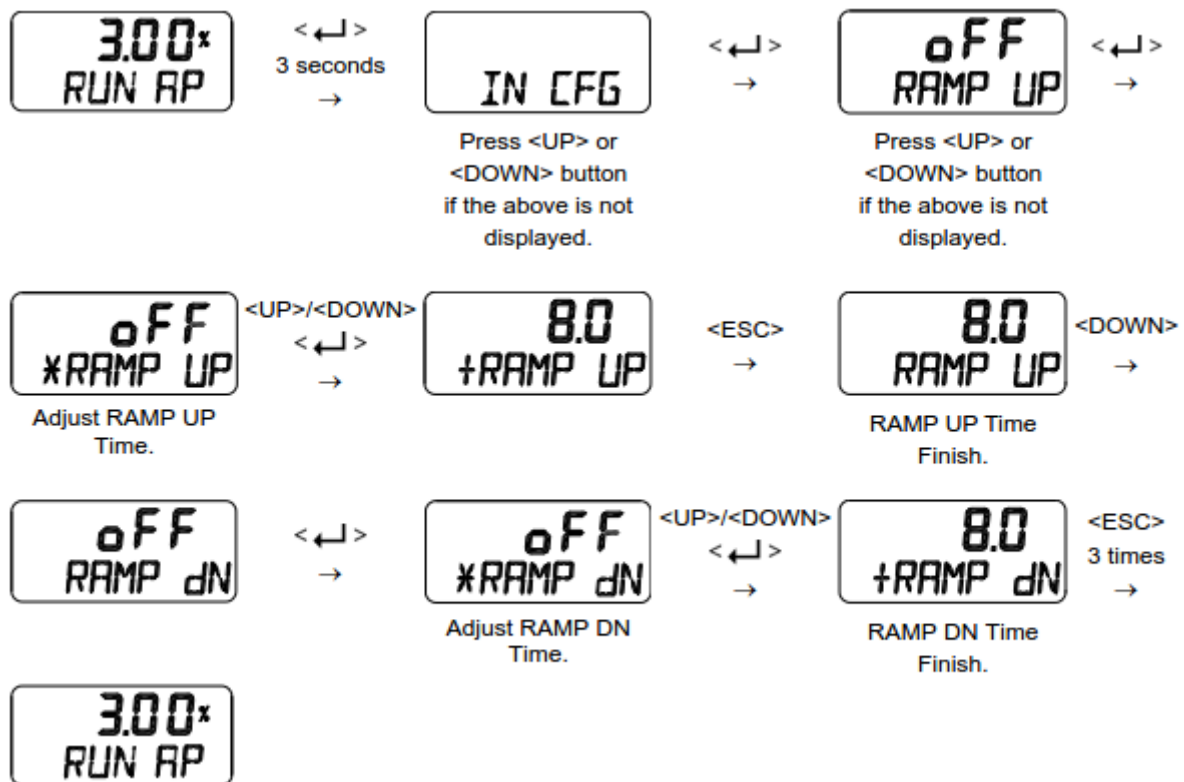

## 6.5 Output Configuration (OUT CFG)

Followings are the values changeable at the Output Configuration Mode.

- 1) Position Transmitter Direction (PTM NORM / REVS)
- 2) Position Transmitter Zero / End (PTM ZERO / ENd)
- 3) HART Feedback Direction (HT NORM / REVS)
- 4) Back Calculation (bACKCAL off / on)

### 6.5.1 Position Transmitter Direction (PTM NORM / REVS)

The analog feedback signal from the positioner can be changed to normal (NORM) or reverse (REVS), which means they are the same or reversed direction as the actual position.



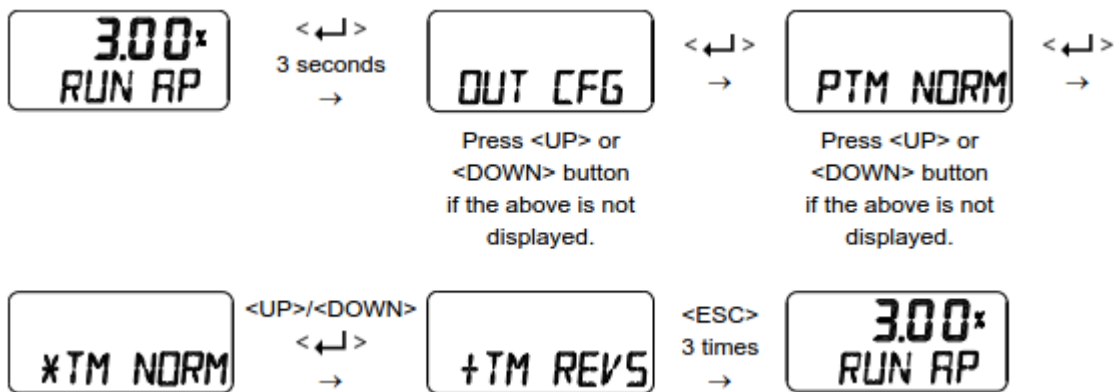

### 6.5.2 Position Transmitter Zero / End (PTM ZERO / ENd)

ZERO adjusts the zero point of the position transmitter (4 mA feedback), and ENd adjusts the end point of the transmitter (20 mA feedback). This is used when the analog output signal needs to be feedbacked differently than the actual position of the valve, or to be adjusted a little. A measuring instrument such as an ampere meter is needed to view the analog output signal, and it should be connected as shown below.

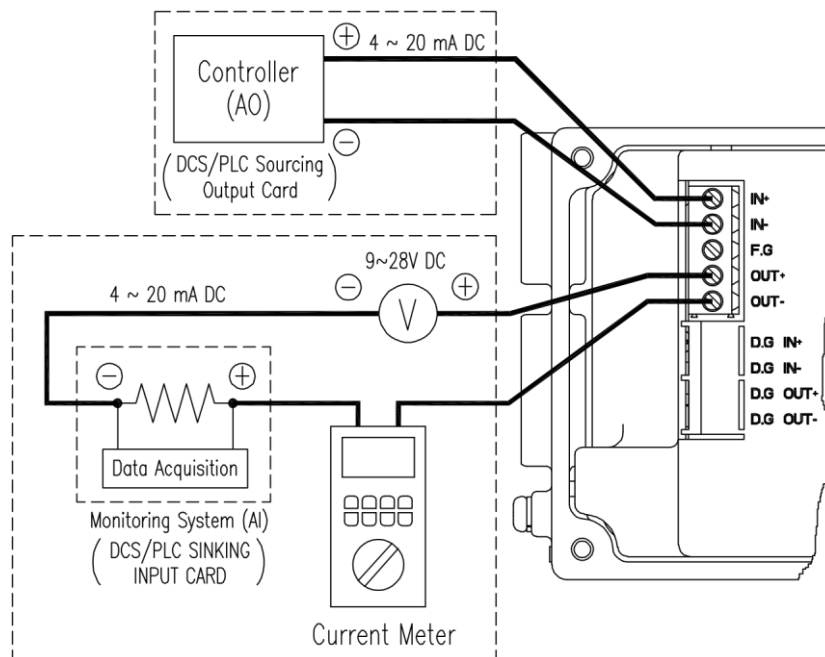
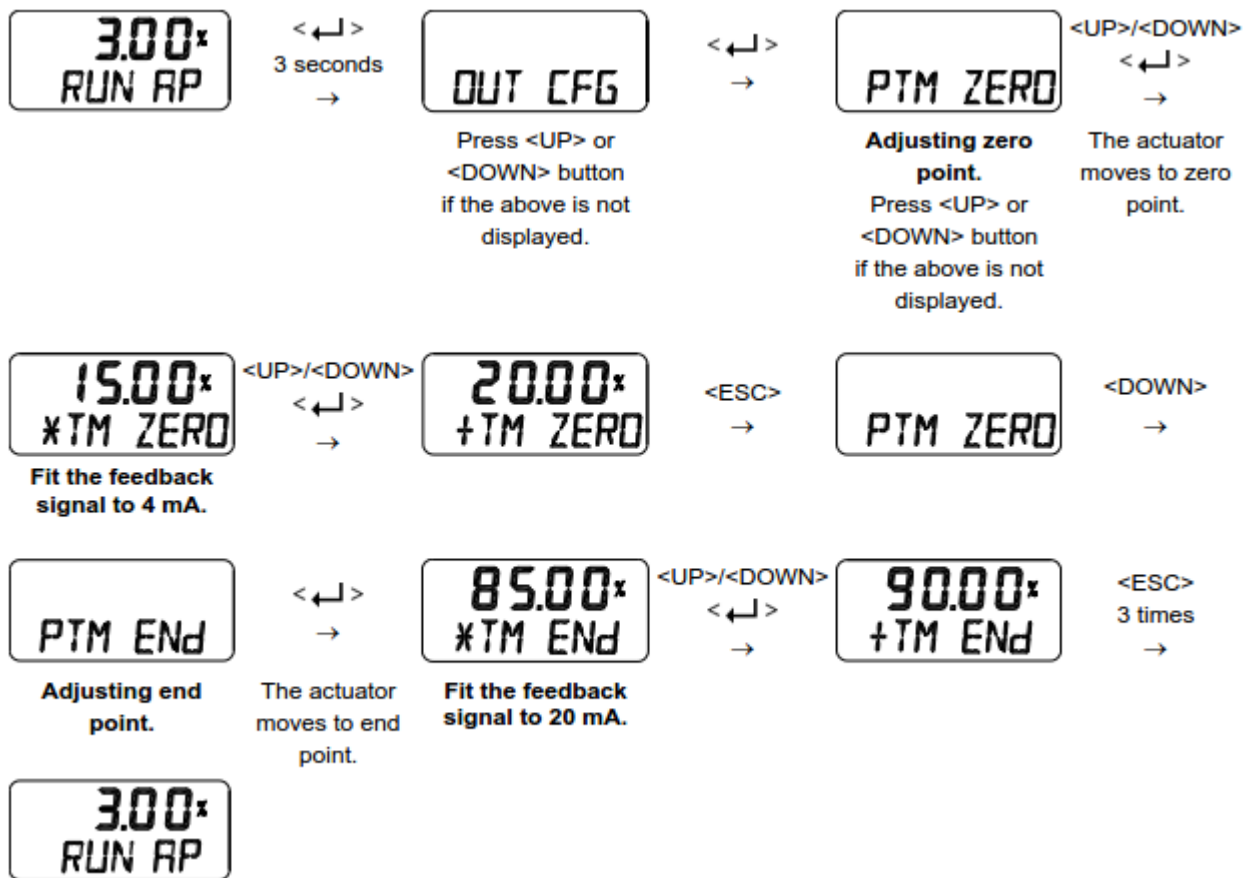
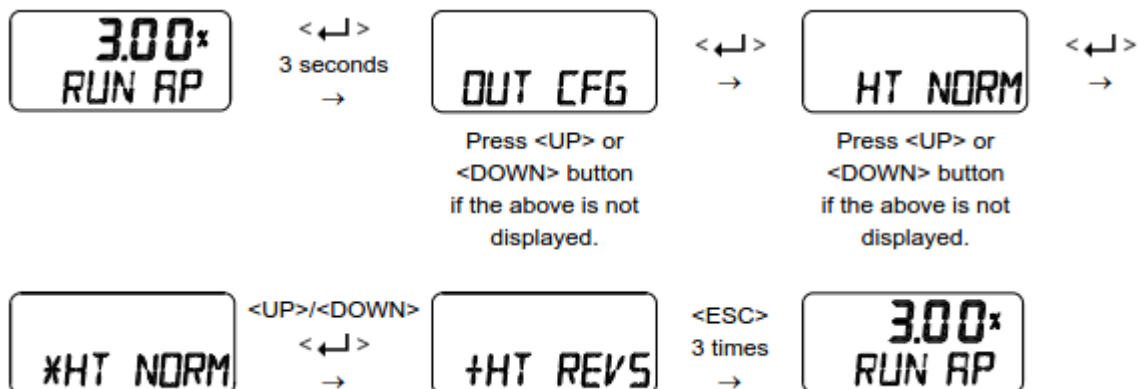

Fig. 9-3: Setting transmitter



### 6.5.3 HART Feedback Direction (HT NORM / REVS)

The feedback signal from the HART communication output of the positioner can be output in the same direction or the reversed direction as the actual position of the valve. NORM or REVS is selected.



### 6.5.4 Back Calculation (bACKCAL oFF / on)

This function recalculates the output "RUN AP" value changed by the flow characteristics setting mode to display it linearly proportional to actual input current. For example, if the flow characteristic mode is set from "LIN" to "EQ", when an input current value of 8 mA (25 %) is applied, the target position is changed

to 6.25 % and "RUN AP" is displayed as 6.25 % after the move. If you change the bACKCAL from OFF to ON, the "RUN AP" is displayed as 25 %.

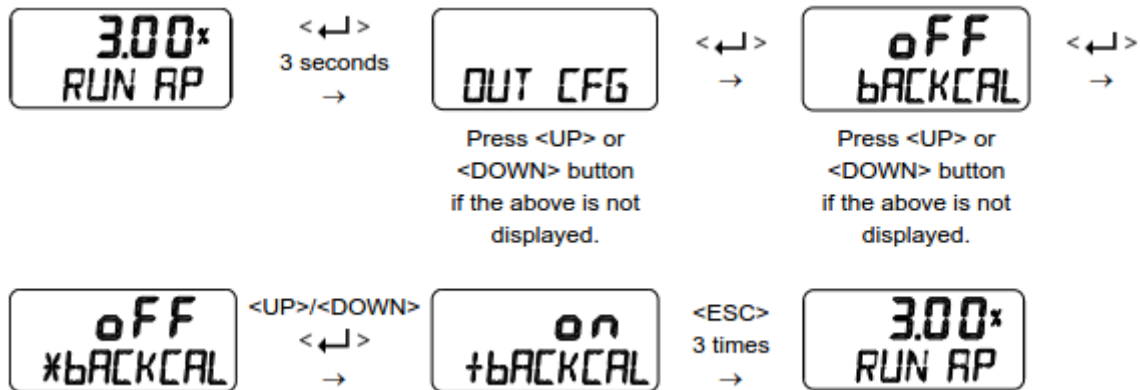

## 6.6 Device Configuration (dEV CFG)

Followings are the values changeable at the dEV CFG Mode.

- 1) Action Setting (ACT REVS / dIR)
- 2) Linear Lever Type (STd / AdT)
- 3) Linear Interpolation (ITP oFF / on)
- 4) Lock of Parameters (Write Protect, W UNLOCK / LOCK)
- 5) Actual Position View Mode (View Mode, VI NORM / REVS)
- 6) Polling address setting (POL AddR 0 ~ 63)
- 7) Factory Reset (dEFAULT oFF / on)
- 8) Positioner Self-Test (SELFTEST)

### 6.6.1.1 Action Setting (ACT REVS / dIR)

Reverse Action (REVS) or Direct Action (dIR) are automatically set by performing "AUTO 2" within the Auto Calibration function. However, this function is used when the user requires to change ACT REVS or ACT dIR to other action. Changing the action from Reverse Action (REVS) to Direct Action (dIR) or Direct Action (dIR) to Reverse Action (REVS) will also change the Signal Direction (SIG), Position Transmitter Direction (PTM), HART Feedback Direction (HT) and View Mode (VI).

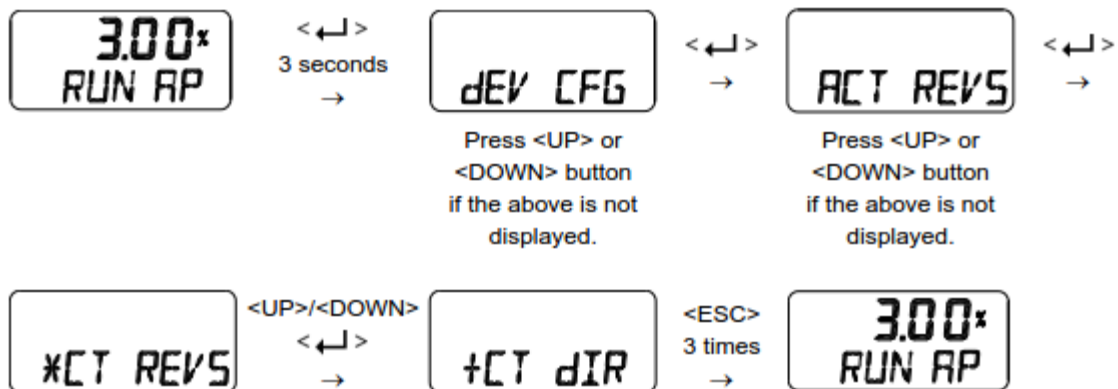

### 6.6.1.2 Linear Lever Type (LEVT STd / AdT)

Displays or changes current linear lever type into standard type or adapter type. If the Lever type mode is set correctly, the accuracy will be worse at ITP ON than at ITP OFF.

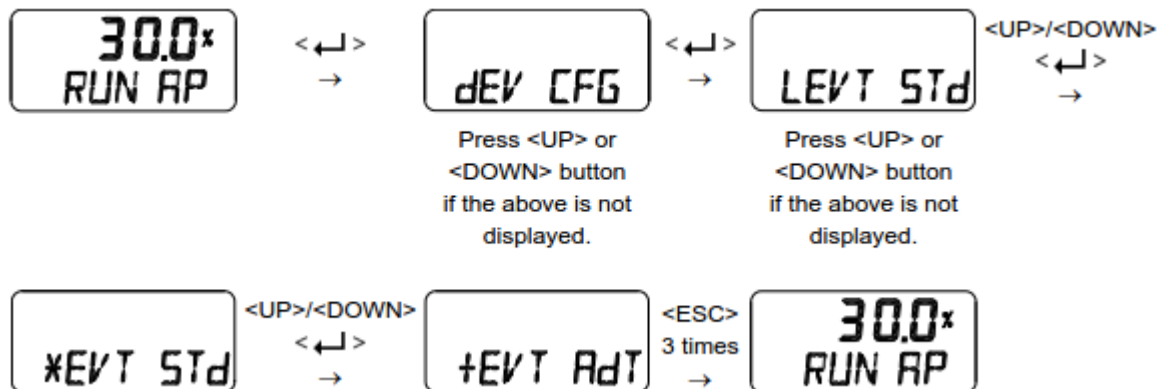

### 6.6.1.3 Linear Interpolation (ITP oFF / on)

ITP is used to compensate the linear motion of the actuator into rotary motion of the feedback lever. Following Auto Calibration, the ITP mode is set automatically to “on” when the angle range of the feedback lever is greater than 20 °, but it is set to oFF when this angle is less than 20 ° or rotary positioner is used.

The settings below are the process of manually changing the “ITP oFF” to the “ITP on”.

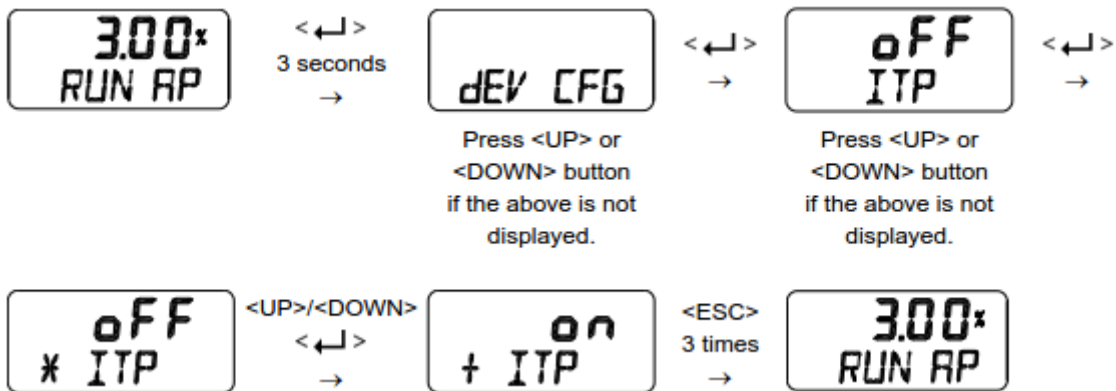

#### 6.6.1.4 Lock of Parameters (Write Protect, W UNLOCK / LOCK)

This function is used to set (LOCK) or disable (UNLOCK) the lock for the parameters. Used to prevent the stored parameters from being changed.

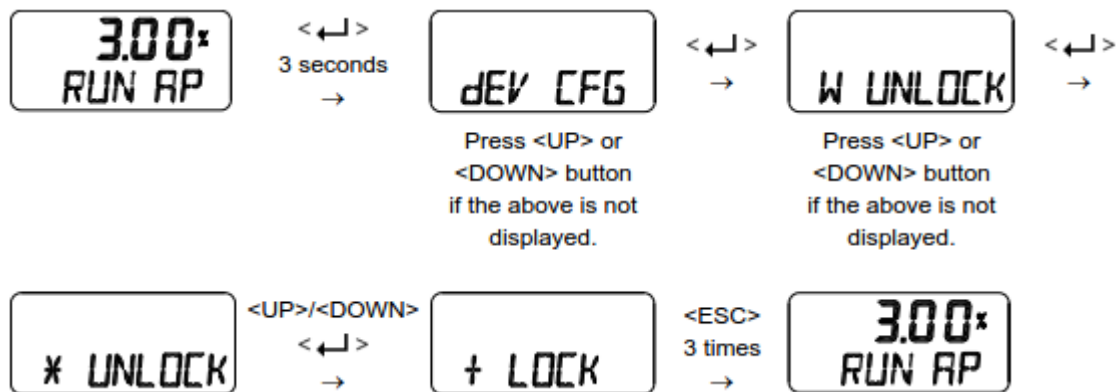

#### 6.6.1.5 Actual Position View Mode (View Mode, VI NORM / REVS)

This function is used to set the "RUN AP" value on the LCD to be displayed as direct (NORM) or reversely (REVS) as the actual position of the valve.

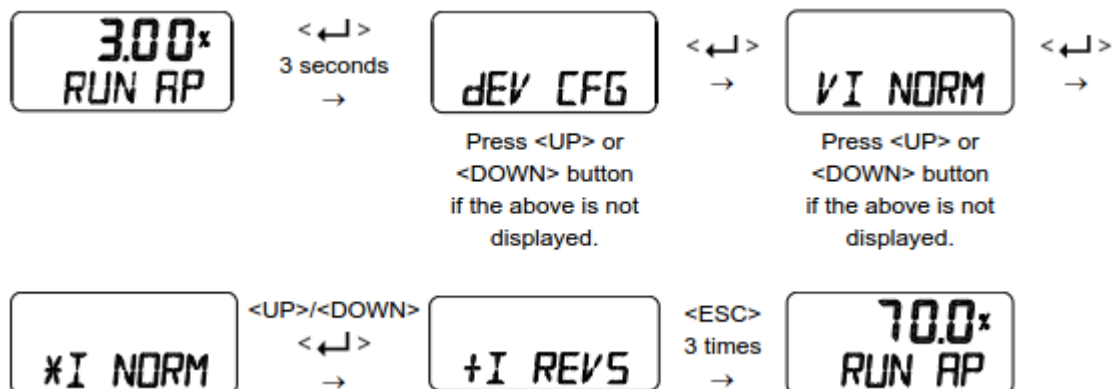

### 6.6.1.6 Polling address setting (POL Addr)

This function is used to set the address value of the positioner on HART(Highway Addressable Remote Transducer) communication. The value from 0 to 63 could be set and default is 0.

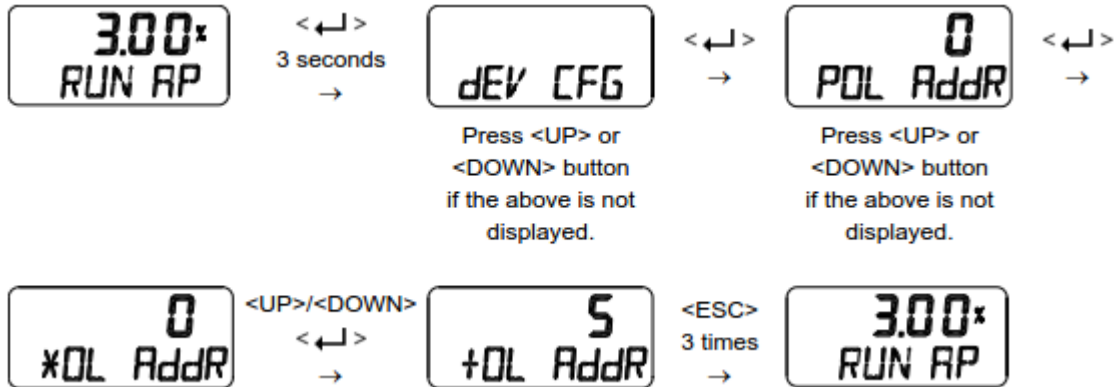

### 6.6.1.7 Factory Reset (dEFAULT oFF / on)

This function initializes all parameters stored in the positioner to initial factory setting. In the dEFAULT mode, press the Enter button to enables ON/OFF setting and then pressing Enter button for approximately 3 seconds changes the dEFAULT mode from oFF to "on". Additional pressing of Enter button resets all parameters to initial factory state.



**Pay attention when using this mode as all the parameter values will be changed to the factory settings.**

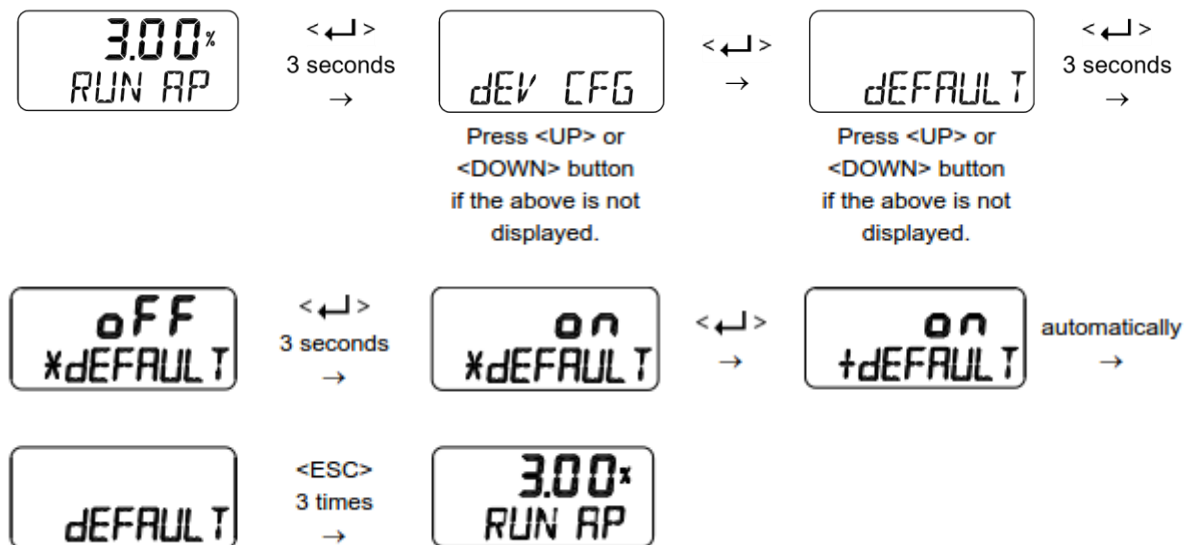

### 6.6.1.8 Positioner Self-Test (SELFTEST)

This function is used to diagnose the operation of the memory (RAM or NVM) inside the positioner. If no error is found during SELFTEST, the SELFTEST menu is displayed after FINISH is displayed, and if abnormalities are detected, the message "SEt / NVMW" is displayed.

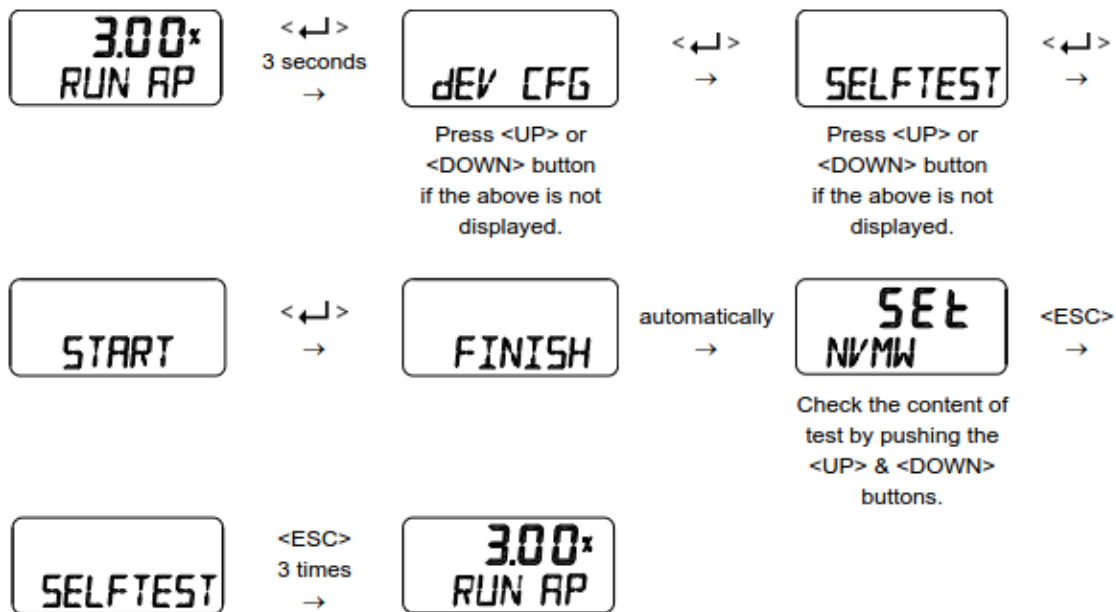

# Diagnostic message

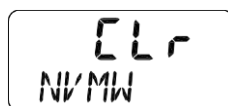

If the abbreviation displayed at the top line is "Set", it means the event has been created, and if it is "CLr", the message has been cleared. NVMW at the bottom is an alarm message that has occurred. See "9.15 Status and Alarm Code" for alarm details.

### 6.6.2 Diagnosis Mode (dIAGNd)

Followings are the values changeable at the dIAGNO Mode.

- 1) Default Alarm Settings
- 2) Process Status (PS)
- 3) Device Status (dS)
- 4) View Monitoring Counts (VI CNTS)
- 5) Diagnostic Limit Configuration (LIMT CFG)
- 6) Reset Alarm Status (RST ALRM)
- 7) View Event Log (EVT LOG)
- 8) Partial Stroke Test Record (View PST Result Record, PST RSLT)
- 9) PST Configuration (PST CFG)
- 10) Run PST (PST NOW)

## 11) Periodic PST Test (PST Schedule, PST SCHd)

**6.6.2.1 Default Alarm Settings**

The table below shows the initial values set at factory for handling the positioner status or associated process conditions. Each status or alarm is set to one of the Failure, Out of Specification, Maintenance Required, or Functional Check at factory, so that the corresponding NE107 symbol is displayed when a specific alarm occurs. This setting is not user-reconfigurable. As shown in the table below, the status / alarms that can be manually reset without removing the cause are Auto Calibration Running, Critical NVM Fail, Non-Critical NVM Fail, PST Fail and Auto Calibration Fail. The two alarms below can be activated even by using the LCD screen and button without intervention of DD or DTM.

- Travel High Limit, Travel Low Limit

**Note 1. NE107 signal is not reconfigurable.**

Status / Alarm	Default setting	Default NE107 signal	Resettable manually when alarm occurred?
Local Operation Active	<b>Enable</b>	Functional Check	No
Auto Calibration Running	<b>Enable</b>	Functional Check	Yes
PST Running	<b>Enable</b>	Functional Check	No
Position Sensor High Limit	<b>Enable</b>	Out of Specification	No
Position Sensor Low Limit	<b>Enable</b>	Out of Specification	No
Critical NVM Fail	<b>Enable</b>	Failure	Yes
Non Critical NVM Fail	<b>Enable</b>	Failure	Yes
Travel High Limit	Disable	Out of Specification	No
Travel Low Limit	Disable	Out of Specification	No
Deviation Timeout	<b>Enable</b>	Out of Specification	No
PST Fail	<b>Enable</b>	Failure	Yes
Travel Cutoff High Limit	<b>Enable</b>	Out of Specification	No
Travel Cutoff Low Limit	<b>Enable</b>	Out of Specification	No
Not Calibrated	<b>Enable</b>	Maintenance Required	No
Auto Calibration Fail	<b>Enable</b>	Maintenance Required	Yes
Loop Current Low Limit	<b>Enable</b>	Failure	No



### 6.6.2.2 Process Status (PS)

The status of the current process is indicated as GOOD, NE107 symbol, and abbreviation for alarm.

NE107 symbols	Abbreviation	Function
None	PS GOOD	Good
	PS FAIL	Failure
	PS FUNC	Functional Check
	PS OUTS	Out of Specification
	PS MNTR	Maintenance Required



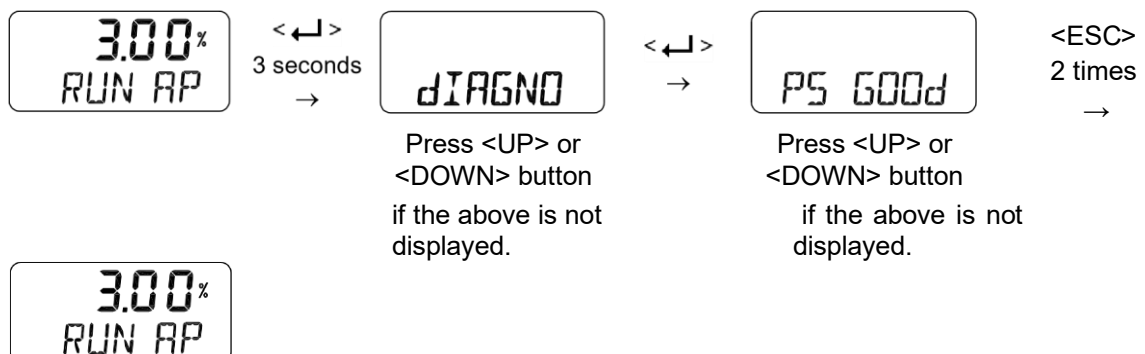

The table below shows the type of the process status or alarm and its abbreviations. See 9.15 Status and Alarm Code for the details of each alarm.

Process Alarm	Abbreviation
Travel High Limit	TVLH
Travel Low Limit	TVLL
Deviation Timeout	dVTO
Travel Cutoff High Limit	TVCH
Travel Cutoff Low Limit	TVCL
Loop Current Low Limit	LPCL



### 6.6.2.3 Device Status (dS)

The status of the current device is indicated as GOOD, NE107 symbol, and abbreviation for alarm.

NE107 symbols	Abbreviation	Function
None	dS GOOd	Good
	dS FAIL	Failure
	dS FUNC	Functional Check
	dS OUTS	Out of Specification
	dS MNTR	Maintenance Required

The table below shows the type of the device status or alarm and its abbreviations. See 9.15 Status and Alarm Code for the details of each alarm.

Device Alarm	Abbreviation
Loop Operation Active	LOPA
Auto Calibration Running	CALR
PST Running	PSTR
Position Sensor High Limit	PSNH
Position Sensor Low Limit	PSNL
Non-Critical NVM Fail	NVMW
Not Calibrated	NCAL
Auto Calibration Fail	CALF
PST Fail	PSTF



### 6.6.2.4 View Monitoring Counts (VI CNTS)

It is used to just view the accumulated data information for valve movement up to now.

Counter Name	Abbreviation [unit]	Function
Cycle Count	CYCL CNT	The accumulated number of times the valve has changed its direction. It is accumulated only when the valve change direction while Cycle Count Deadband is exceeded.
Travel Accumulator	TVL ACUM [%]	The total valve travel accumulated whenever Travel Accumulator Deadband is exceeded.
Operating Count	OPER CNT	Total number of input change applied to I/P converter.
Fully Open Count	FOP CNT	The accumulated number of times the valve has been fully open.
Fully Closed Count	FCL CNT	The accumulated number of times the valve has been fully closed.

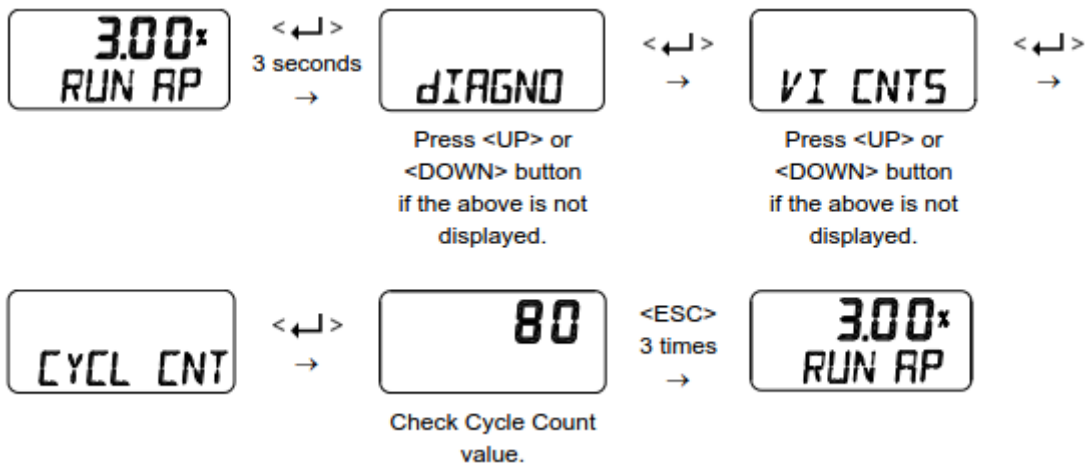

### 6.6.2.5 Diagnostic Limit Configuration (LIMIT CFG)

This configuration is used to set the upper or lower limit that is generated by the Travel High Limit Alarm and Travel Low Limit Alarm. Even if this condition is met, the corresponding alarm will not be triggered if the alarm(s) is not enabled.

Upper / Lower Limit or Enable	Abbreviation [unit]	Description
Travel High Limit	TVL HI [%]	Alarm is triggered if the valve stroke exceeds TVL HI. The initial factory setting is 100%.
Travel Low Limit	TVL LO [%]	Alarm is triggered if the valve stork is lower than TVL LO. The initial factory setting is 0 %.
Travel High Limit Alarm Enable	AL TVLH	These are used to set "on" or "oFF" for each alarm. When set to oFF, the alarm does not occur even if the conditions are met. All the initial factory settings are oFF.
Travel Low Limit Alarm Enable	AL TVLL	

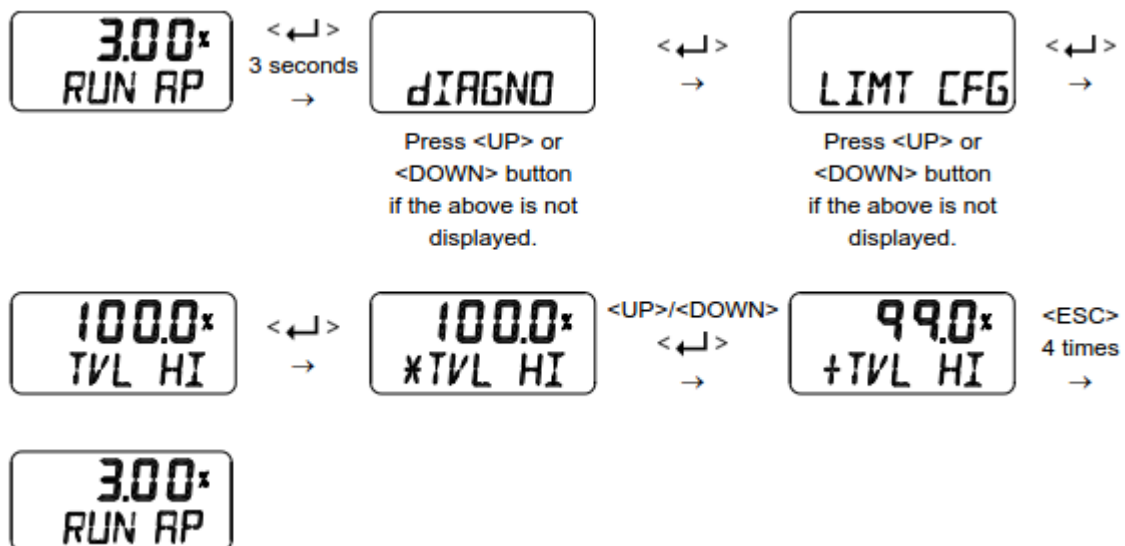

### 6.6.2.6 Reset Alarm Status (RST ALRM oFF / on)

The alarm is automatically released when the cause of the alarm is removed. For example, if the Partial Stroke Test fails or Auto Calibration fails, use this function to release the alarm.

Below is an alarm list that can be released using the RST ALRM function.

- 1) Auto Calibration Running
- 2) Non-Critical NVM Fail
- 3) PST Fail
- 4) Auto Calibration Fail

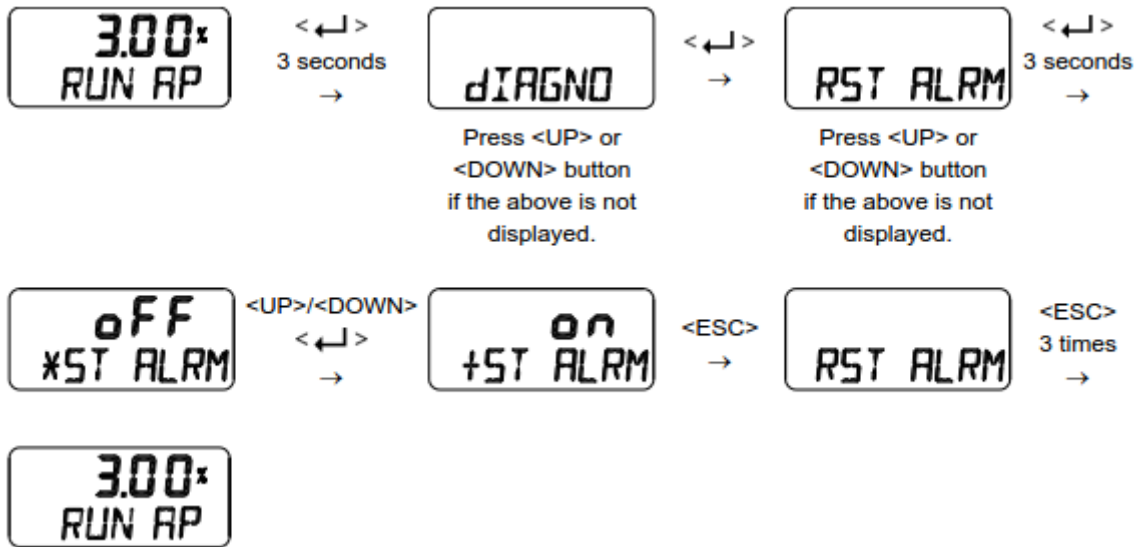

### 6.6.2.7 View Event Log (EVT LOG)

This is used to show the 20 most recent events that occurred in operation. Record 0 is the most recent of the 20 events and Record 19 is the oldest event. The event detail shows the time when the event occurred (EVT TIME) as well as the content of the event (EVT INFO). See 9.15 Status and Alarm Codes for an abbreviation and description of the event details.

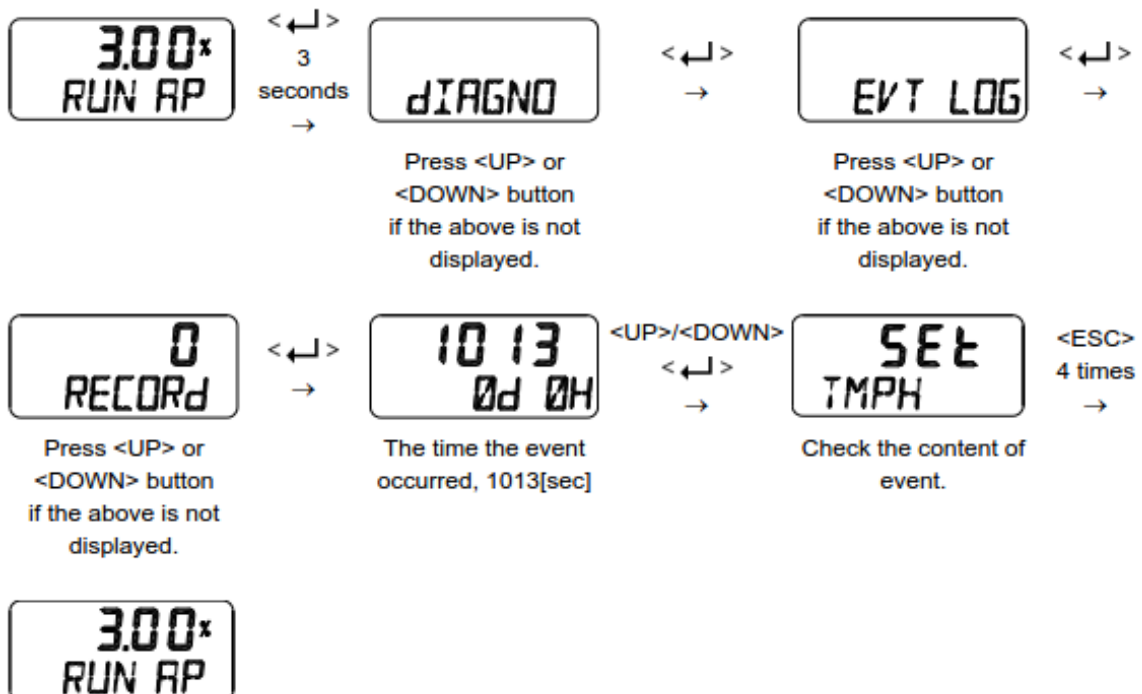

### # Event Message Description



The "SEt on the upper section of screen shows that a specific event has occurred, while the "CLr" means that the event has been removed. The "TMPH" displayed on the bottom section indicates an abbreviation for the alarm.

#### 6.6.2.8. Partial Stroke Test Record (View PST Result Record, PST RSLT)

This is used to show information about the 10 most recent Partial Stroke Tests performed. Record 1 is the most recent of the 10 PST histories, and Record 10 is the result of the oldest PST operation. The response time (RT), response code (RC), and dead time (dT) after the PST operation are also shown. Response time represents the time to reach the target position from the PST start, and deadtime indicates the time from the start of the PST command to the moment the valve starts to move. The table below describes the response codes.

Name of RC	Response Code (RC)		Description
Pass	PASS	1	Pass
Out Of Tolerance	OOT	2	Out of Tolerance : When PST is executed, the AP (actual position) is out of PST tolerance compared to the PST start position value.
PST Time Out	PSTO	3	Time Out : Aborted if the AP fails to move to the Target Position within PST Limit Time during PST execution.
Abort	AbOT	4	Abort, but reserved
Hunting	HUNT	5	Hunting occurs during the test.
Abnormal Shutdown	AbSd	6	Abnormal Shutdown : An unexpected problem occurred during the test.
Loop Current Low	LPCL	256	PST execution is stopped due to a change in the input signal (0.8 mA (5%) or more).
Stop By Digital Input	STdI	512	Stopped by Digital Input Function (dIF)

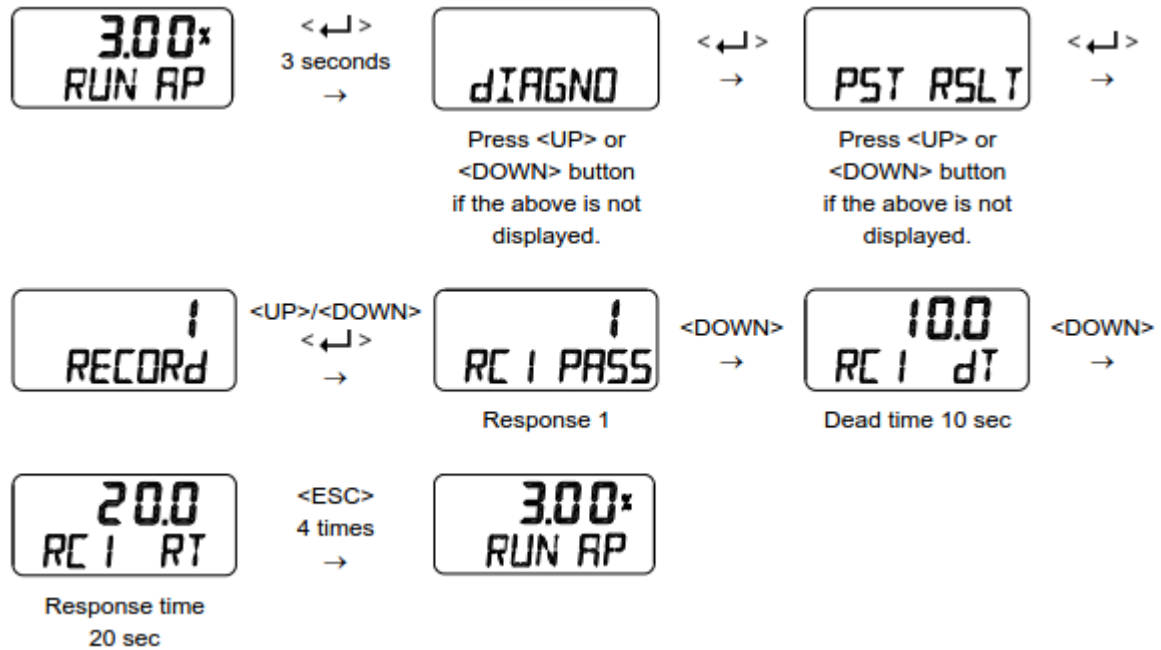

### 6.6.2.9 PST Configuration (PST CFG)

Parameter names	Abbreviation [unit]	Description
PST Interval	INTERVAL [days]	Sets time interval PST is triggered. Initial factory setting is 365 days.
PST Start Position	START PO [%]	Sets the start position to launch PST. Initial factory setting is 100 %.
PST Tolerance	TOL [%]	The allowable tolerance for the start position. PST Failure alarm is triggered as Out of Tolerance(OOT) when actual position exceeds the tolerance. Initial setting is 5 %.
PST Target Position	TARGET [%]	Target position. Initial factory setting is 90 %.
PST Hold Time	HOLD TM [sec]	Sets hold time after target position ( $\pm 2$ %) is reached Initial factory setting is 5 sec.
PST Limit Time	LIMT TM [sec]	PST Failure alarm is triggered as Limit Time Over (LTO) when target position is not reached within LIMT TM after starting PST. Initial factory setting is 10 sec.
PST Ramp Up Rate	RAMP UP [%/sec]	Sets ramp rate when the valve moves from the target position to the start position. Initial factory setting is OFF.
PST Ramp Down Rate	RAMP dN [%/sec]	Sets ramp rate when the valve moves from the start position to the target position. Initial factory setting is OFF.

Remaing PST Time	NEXT PST [days.hrs]	Based on the current time, the remaining time to start PST is displayed by Days and Time.
------------------	------------------------	---

Graph below shows PST target position (TP) and actual position (AP) when applying PST Start Position 100 %, Target Position 90 %, Hold Time 10 sec, PST Ramp up Rate 0.5 %/sec, PST Ramp down Rate 0.5 %/sec.



<div style="border: 1px solid black; padding: 5px; display: inline-block;"> <b>3.00%</b> RUN AP         </div>	<↵> 3 seconds →	<div style="border: 1px solid black; padding: 5px; display: inline-block;"> <b>DIAGNO</b> </div>	<↵> →	<div style="border: 1px solid black; padding: 5px; display: inline-block;"> <b>PST CFG</b> </div>	<↵> →
Press <UP> or <DOWN> button if the above is not displayed.		Press <UP> or <DOWN> button if the above is not displayed.			
<div style="border: 1px solid black; padding: 5px; display: inline-block;"> <b>365</b> INTERVAL         </div>	<↵> →	<div style="border: 1px solid black; padding: 5px; display: inline-block;"> <b>365</b> *INTERVAL         </div>	<UP>/<DOWN> <↵> →	<div style="border: 1px solid black; padding: 5px; display: inline-block;"> <b>65</b> +INTERVAL         </div>	<ESC> 4 times →
<div style="border: 1px solid black; padding: 5px; display: inline-block;"> <b>3.00%</b> RUN AP         </div>					



### 6.6.2.10 Run PST (PST NOW)

PST NOW is used to perform Partial Stroke Test promptly in accordance with the conditions set in Chapter 6.6.2.8

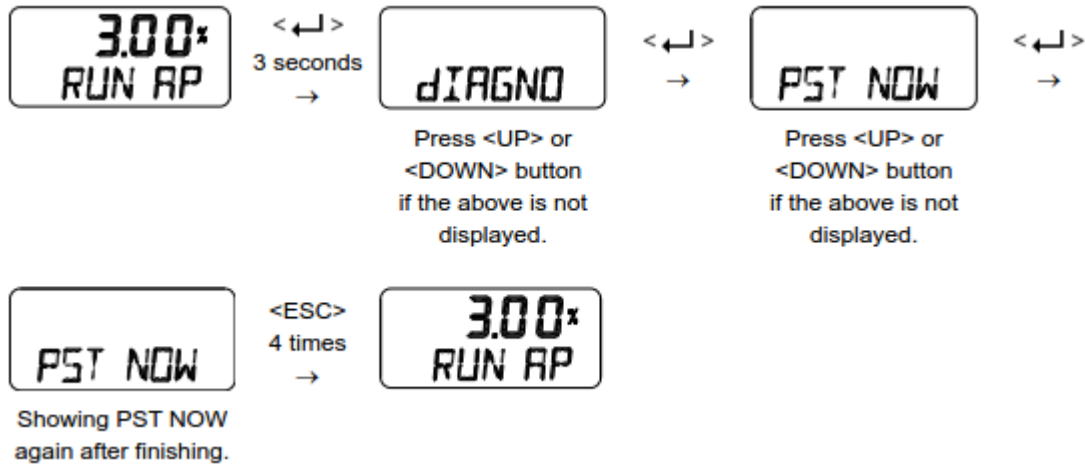

### 6.6.2.11. Periodic PST Test (PST Schedule, PST SChd OFF / on)

When PST SChd is set to ON, the Partial Stroke Test is executed regularly under the conditions set in 9.12.9 above. For example, PST is performed every 365 days when PST Interval is set to 365 days. The initial factory setting is OFF.

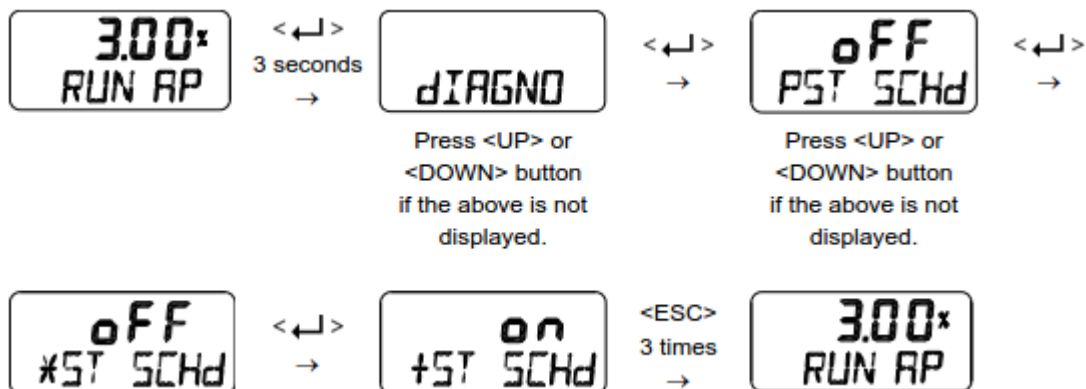

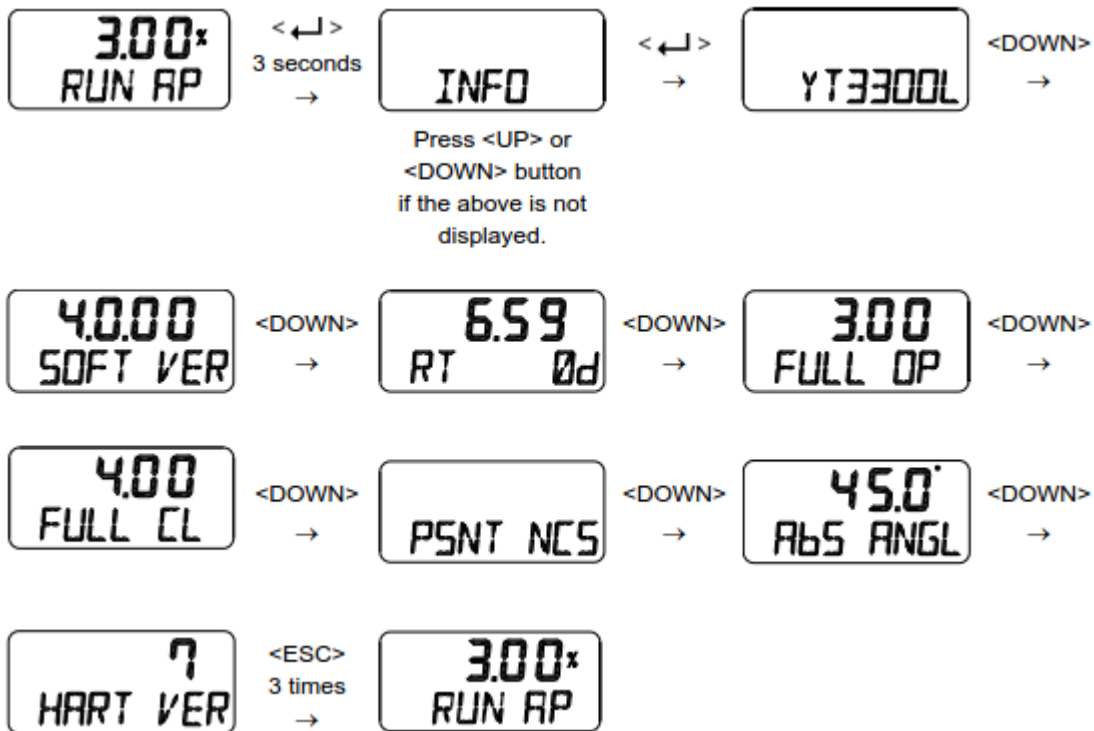
**6.6.3 Position information (INFO)**

LCD display	Description
<b>3300</b>	Model Name
<b>4.000 SOFT VER / 2022JA31</b>	Software Version [SOFT VER] "4.0.00" Software Input date : "2022-01(JA)-31" (January JA, February FB, March MR, April AR, May MY, June JN, July JL, August AG, September SP, October OT, November NV, December DC) At SOFT VER status if <LEFT> button is pressed, the date will be displayed and then if <LEFT> button is pressed again, SOFT VER is displayed again.
<b>4.18 RT 0d</b>	Run Time [RT] Total usage time of the product Upper "4.18" indicates 4 hours and 18 minutes. Lower "0d" indicates days used. Interval to store time is one hour.
<b>3.12 FULL OP</b>	Upward Full Stroke Time [FULL OP] This value is stored automatically after executing AUTO 2 calibration, and indicates the time in seconds it takes for the valve to fully open from fully closed.

<b>2.97 FULL CL</b>	Downward Full Stroke Time [FULL CL] This value is stored automatically after executing AUTO 2 calibration, and indicates the time in seconds it takes for the valve to fully closed from fully open.
<b>PSNT NCS</b>	Position Sensor Type [PSNT] Potentiometer [PTN] Non-Contact Sensor [NCS]
<b>AbS ANGL</b>	Absolute Position in Angle [ABS ANGL].
<b>HART VER</b>	HART Protocol Revision [HART VER]

#### 6.6.4 Error codes during automatic calibration

The error detected during the automatic calibration is displayed on LCD especially when the positioner may become out of control, may malfunction or may become poor in precision. Once it is detected, the auto calibration is aborted.

Error code		Error content and cause	Action
CHK AIR	-7	➤ Indicated when the valve is not moving in "Full Open" direction during auto calibration.	➤ Check if pneumatic pressure is being supplied normally to the positioner.
	-9	➤ Indicated when the valve is not moving in "Full Close" direction during auto calibration.	
	-10	➤ Indicated when there is no response in torque motor.	
	-12	➤ Indicated when oscillation happens in steady state during SCAN 1 phase of auto calibration.	➤ Check for leakage from output port of the positioner and related to piping line.
CHK LINK	-8	➤ Indicated when the movable range of the Feedback lever is too narrow.	➤ Move and re-install the positioner to stem of actuator in order to make the angle use of the feedback lever larger than current use angle.

#### 6.6.5 Status and Alarm Code

Refer to the table below to check the status and alarm codes that can be displayed on LCD screen or HART monitor, and then take the appropriate action.

**Note 1. Any status or alarms assigned to one of NE107 signals at factory is not newly assignable.**

Alarm Code	Abbreviation	Status / Alarm name	Description or proposed actions
0	LOPA	Local Operating Active	It indicates the positioner is being operated by manual operation.
1	CALR	Auto Calibration Running	It is active when auto-calibration is in progress.
2	PSTR	PST Running	It is active when Partial Stroke Test is in progress.
4	PSNH	Position Sensor Hi Limit	Position sensor is out of range. Check the installed state if it happened during operation.
5	PSNL	Position Sensor Lo Limit	
7	NVMW	Non-Critical NVM Defect	It is active if there is a failure associated with NVM (Nonvolatile Memory). Initialize the positioner using Default function and then AUTO 2 calibration. If it is repeated, replace the electronics board by contacting the manufacturer or manufacturer's representative.
13	TVLH	Travel Hi Limit	It is active when the travel exceeds Travel Hi Limit.
14	TVLL	Travel Lo Limit	It is active when the travel falls below Travel Lo Limit.
15	dVTO	Deviation Time Out	It lasts more than 60 seconds with the deviation between the target location and the actual location out of 5%. The deviation time 60 seconds and the deviation 5% are not changeable but fixed. Check if there is no problem with the friction of valve/actuator, pneumatic leaks, insufficient supply pressure.
16	PSTF	PST Failure	It is active when Partial Stroke Test has failed. Remove the cause of the failure after checking the response code of the PST.
23	TVCH	Travel Cutoff Hi Limit	It is active when the travel exceeds the available high stroke of the valve/actuator. The available stroke is already set during auto calibration. The event is not created when Tight Shut Open is used. Aging of the valve / actuator assembly or problem in the positioner sensor.
24	TVCL	Travel Cutoff Lo Limit	It is active when the travel is below the available low stroke of the valve/actuator. The available stroke is already set during auto calibration process. The event is not created when Tight Shut Close is used. Aging of the valve / actuator assembly or problem in the positioner sensor.

Alarm Code	Abbreviation	Status / Alarm name	Description or proposed actions
28	NCAL	Not Calibrated	It is active when auto-calibration has not done after installation. Perform AUTO 2 calibration after checking if the installed state is good.
29	CALF	Auto Calibration Failure	It is active when auto-calibration has failed. Retry autocalibration after checking if there is no problem with installed state such pneumatic leaks, lever position and others.
37	LPCL	Loop Current Lo Limit	It is active if the input current falls below 3.8 mA.
145	VARA	Device Variable Alert	It is active when one of the internal variables are out of range.
144	MNTR	Maintenance Required	It is active when more than one of alarms assigned to "Maintenance Required" have happened. Remove the cause of the alarm after checking it.
147	FAIL	Failure	It is active when more than one of alarms assigned to "Failure" have happened. Remove the cause of the alarm after checking it.
148	OUTS	Out of Specification	It is active when more than one of alarms assigned to "Out of Specification" have happened. Remove the cause of the alarm after checking it.
149	FUNC	Function Check	It is active when more than one of alarms assigned to "Functional Check" have happened. Remove the cause of the alarm after checking it.
-	OVER CUR	Over Current	The input current exceeds 24mA.

7

Main Software Map

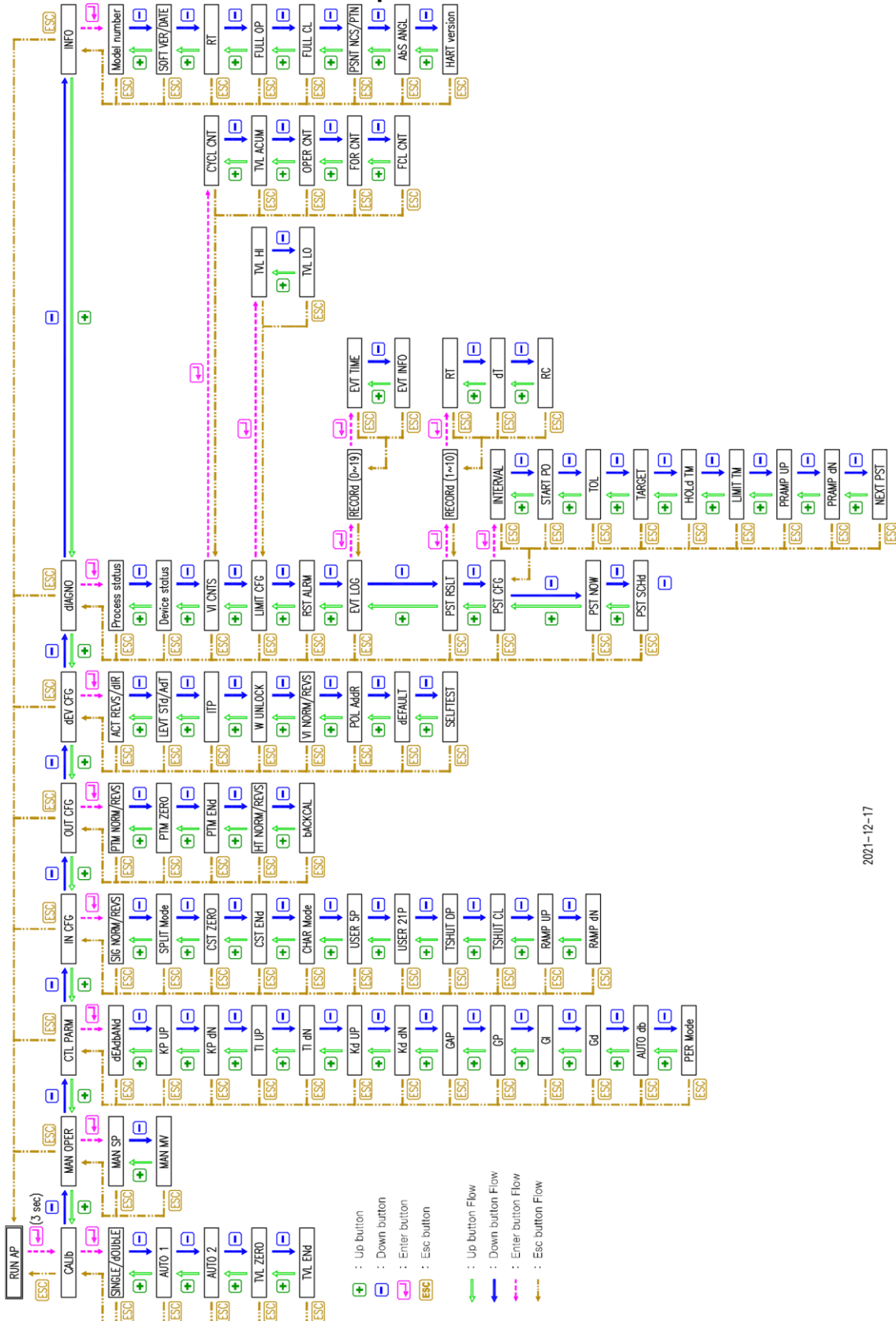

2021-12-17

## 8 Manufacturer contact details:

**If you have questions about this product,  
Please contact the nearest ECON distributor.  
You can find them on [www.eriks.com](http://www.eriks.com)**



**ERIKS Flow Control**  
Cypresbaan 63,  
2908 LT Capelle aan den IJssel,  
The Netherlands

Phone: +31 (0)88 855 8100